

Notes
 Components numbers followed by * indicate part is not populated

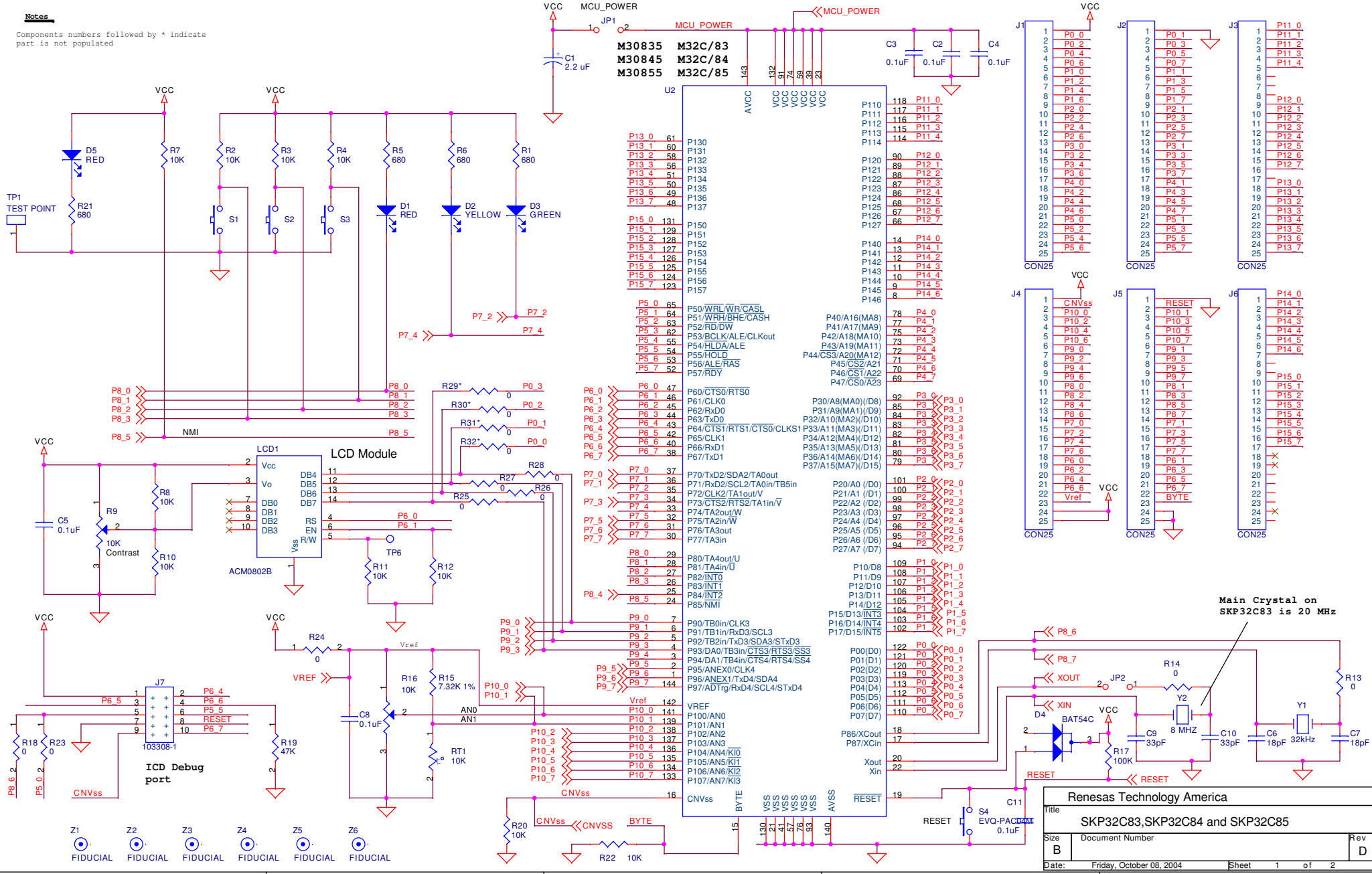

SKP32C83, SKP32C84 and SKP32C85

Document Number: SKP32C83, SKP32C84 and SKP32C85

Rev: D

Date: Friday, October 08, 2004

Sheet 1 of 2