

Title		
R0K51668R001BR		
Size	Document Number	Rev
A3	CPU	3.0
Date:	Monday, February 23, 2009	Sheet 1 of 6

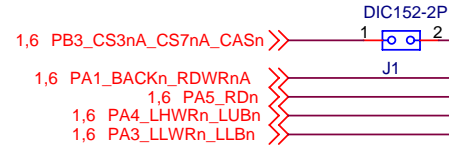

1,6 CPU_A[23:0]

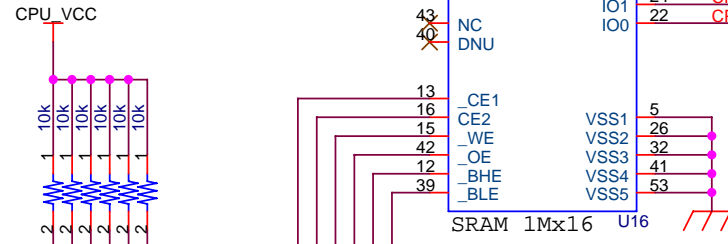
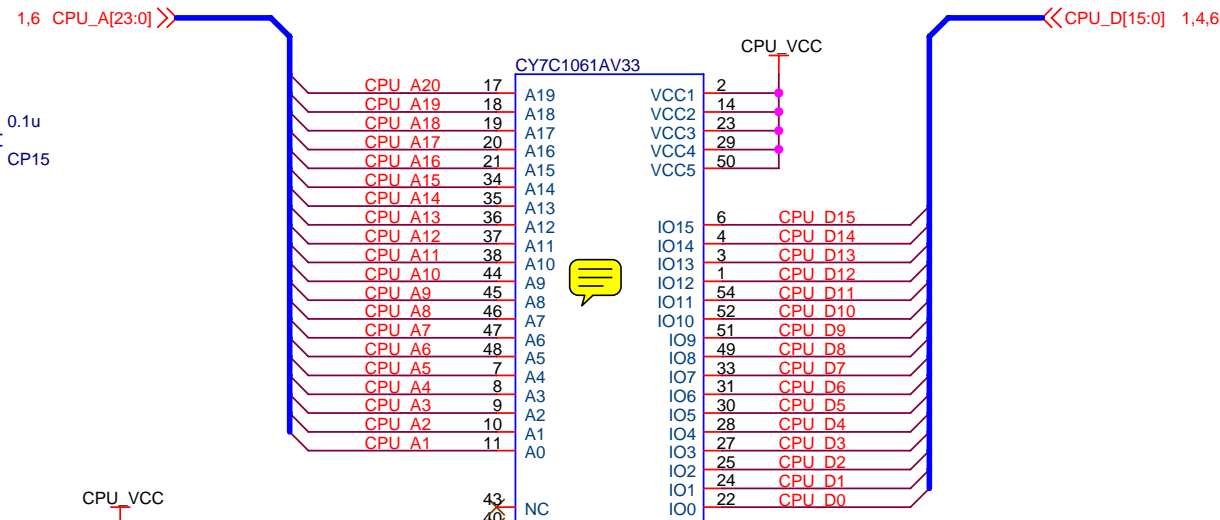
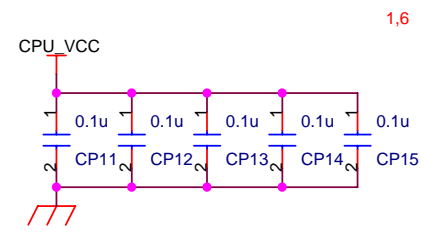
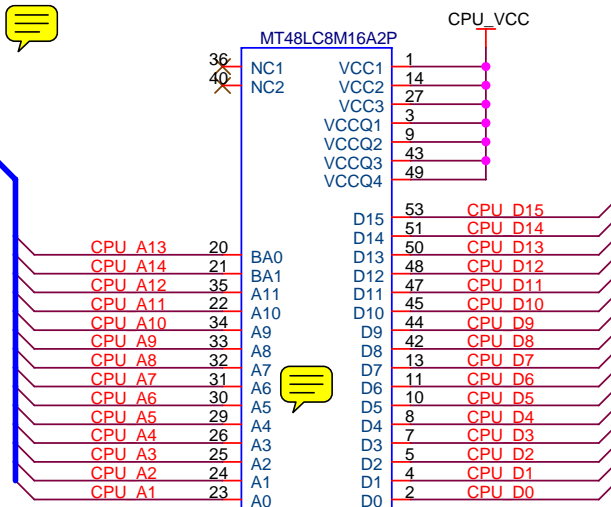

R2.0 connect BA1to A14
connect BA0to A13

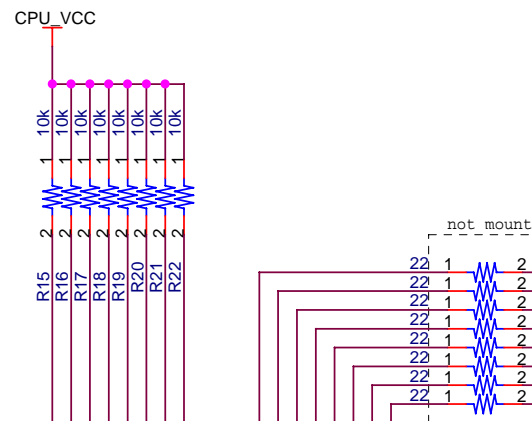

- 1,6 PB1_CS1n_CS2nB_CS5nA_CS6nB_CS7nB
- 1,6 PB2_CS2nA_CS6nA_RASn
- 1,6 PB3_CS3nA_CS7nA_CASn
- 1,6 PB4_CS4nB_WE
- 1,6 PC2_LUCASn_DQMLU
- 1,6 PC3_LLCAsn_DQMLL
- 1,6 PB7_SDRAMPHI
- 1,6 PB5_CS5nD_OEn_CKE

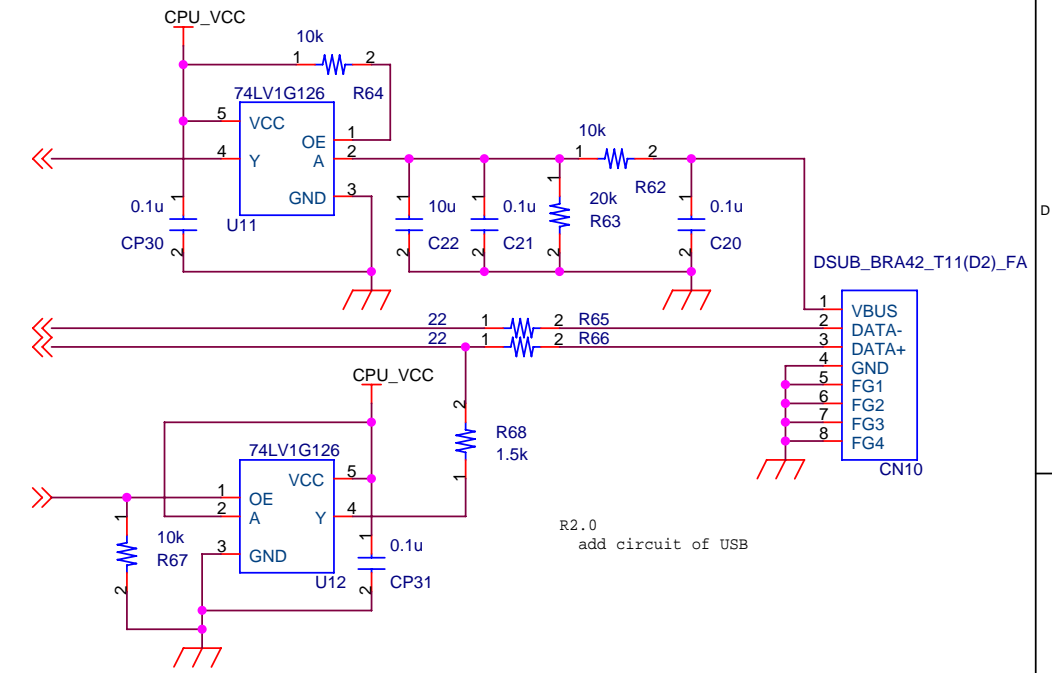

R2.0 add circuit of USB

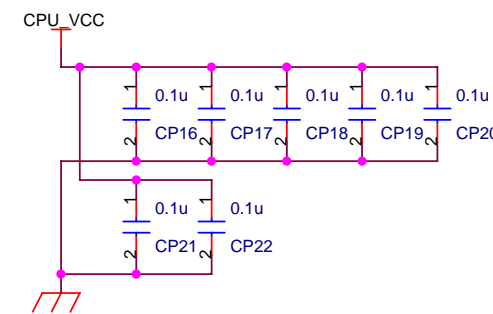

Title		
R0K51668R001BR		
Size	Document Number	Rev
A3	SRAM, SDRAM,USB	3.0
Date:	Monday, February 23, 2009	Sheet 2 of 6

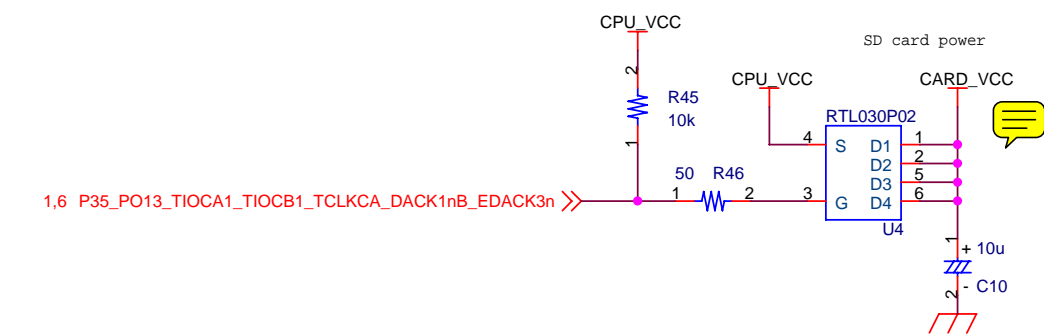
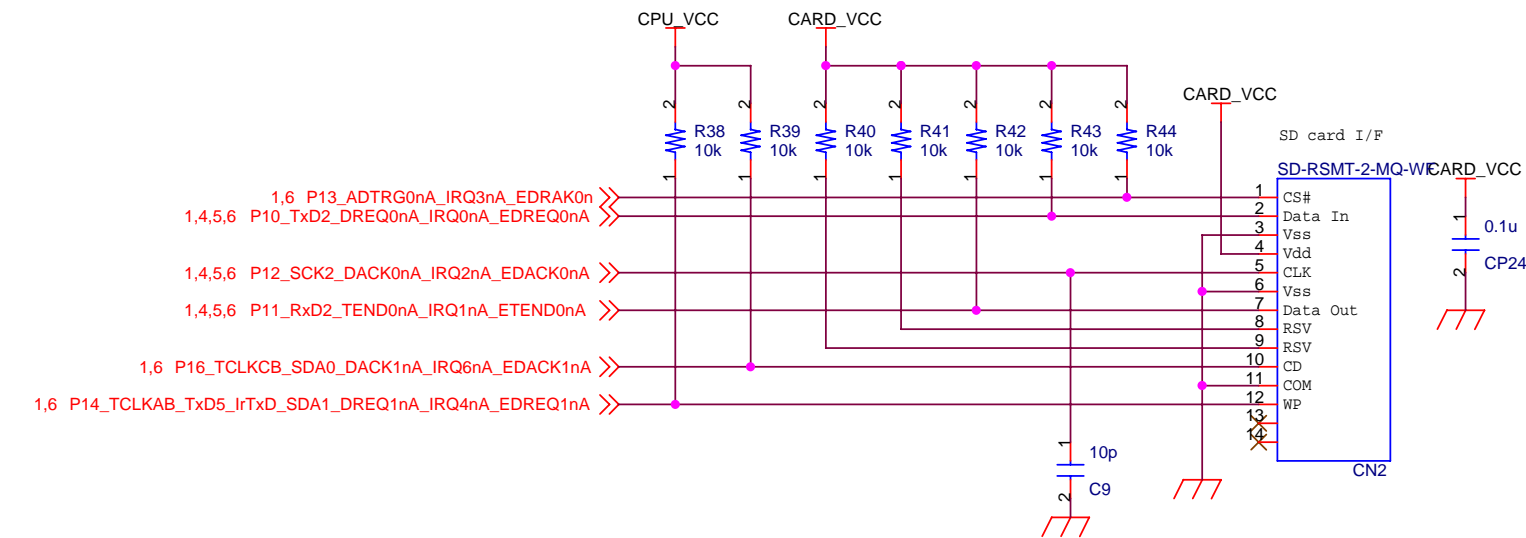
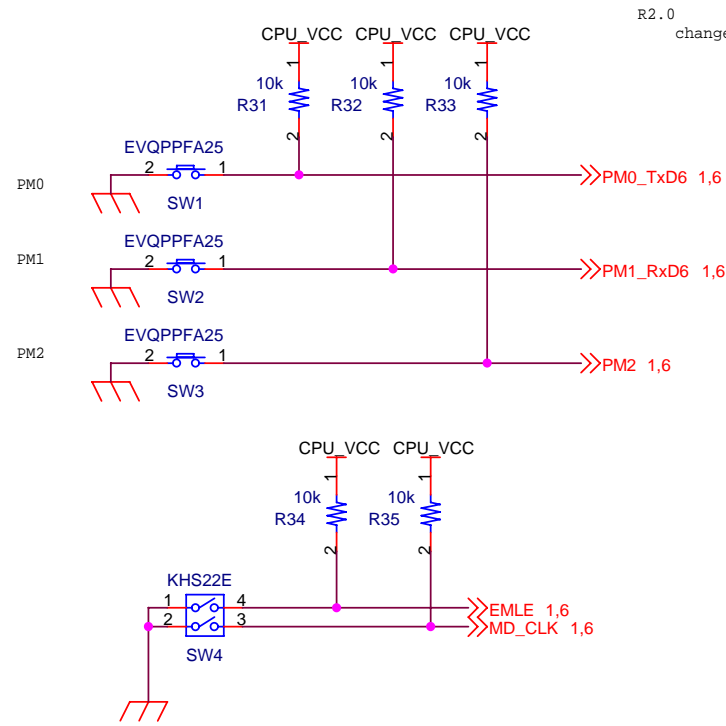

- 1,6 P65_TMO3_DACK3nB_TCK_EDACK1nB
- 1,6 P62_TMO2_SCK4_DACK2nB_IRQ10nB_TRST_EDACK0nB
- 1,6 WDTOVFn_TDO
- 1,6 P63_TMRI3_DREQ3nB_IRQ11nB_TMS_EDREQ1nB
- 1,6 P64_TMC13_TEND3nB_TDI_ETEND1nB

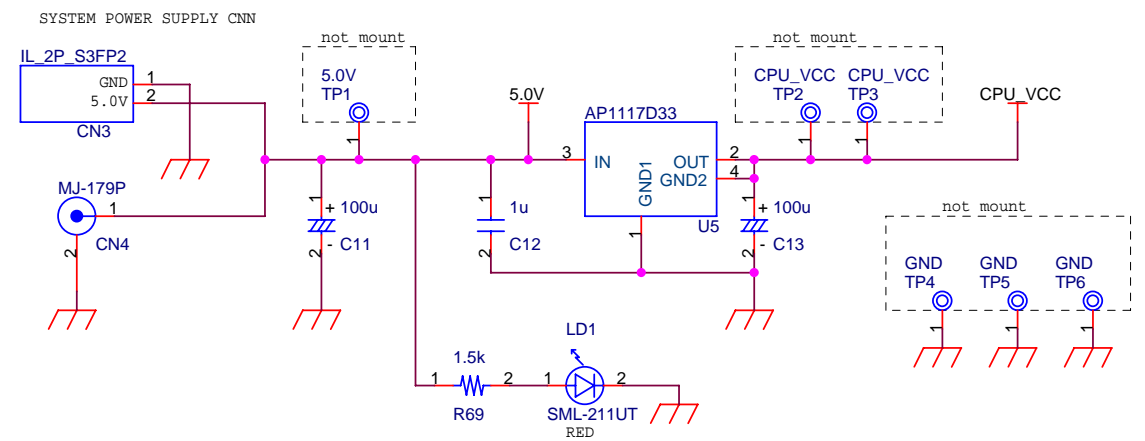
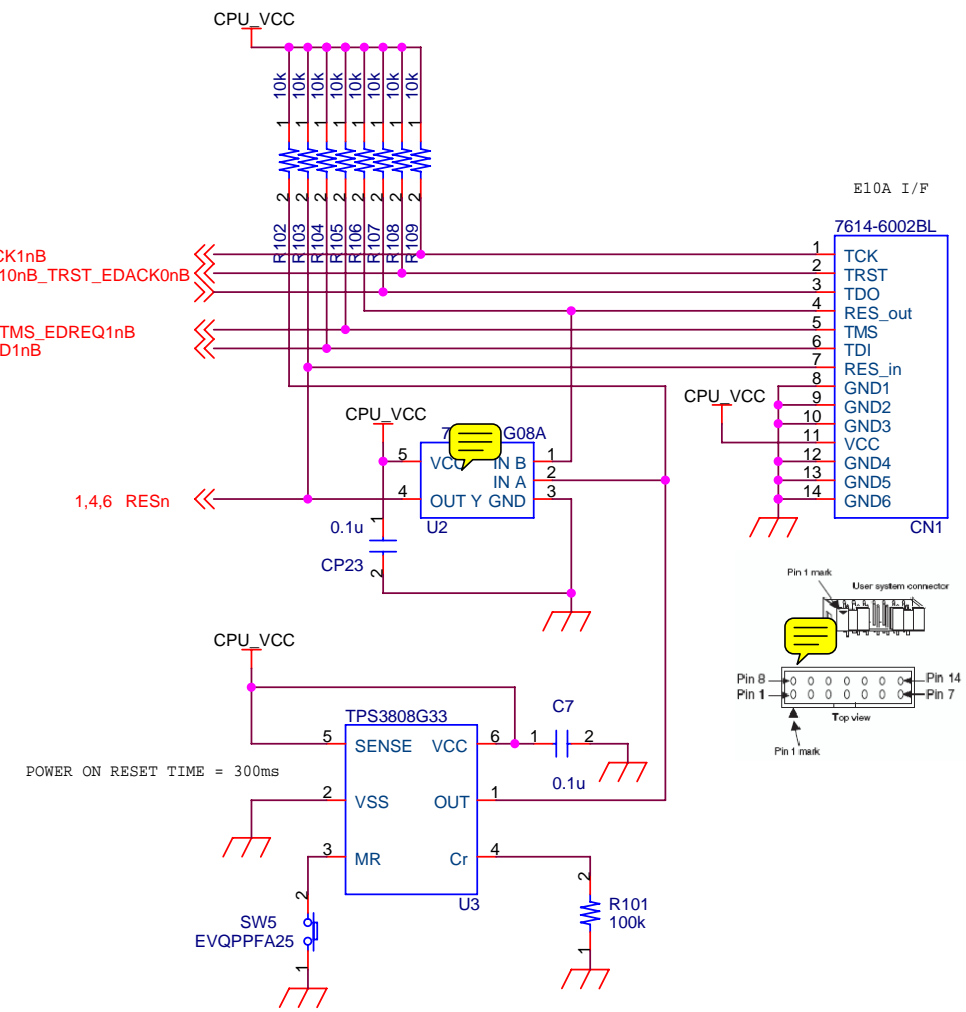

Title		
R0K51668R001BR		
Size	Document Number	Rev
A3	SW, E10A, Reset, SD, Power	3.0
Date:	Monday, February 23, 2009	Sheet 3 of 6

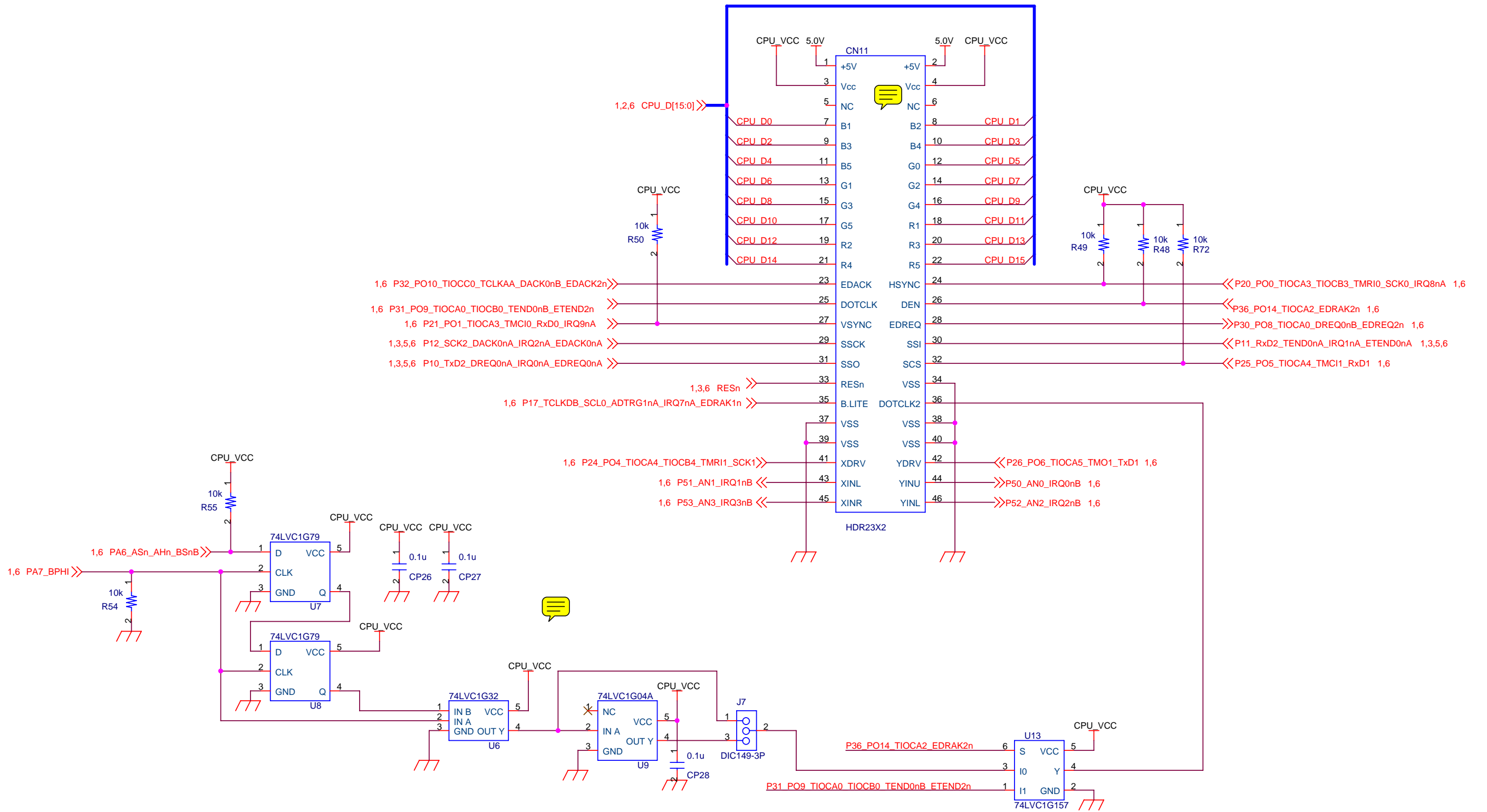

Title		
R0K51668R001BR		
Size	Document Number	Rev
A3	LCD_TouchPanel	3.0
Date:	Monday, February 23, 2009	Sheet 4 of 6

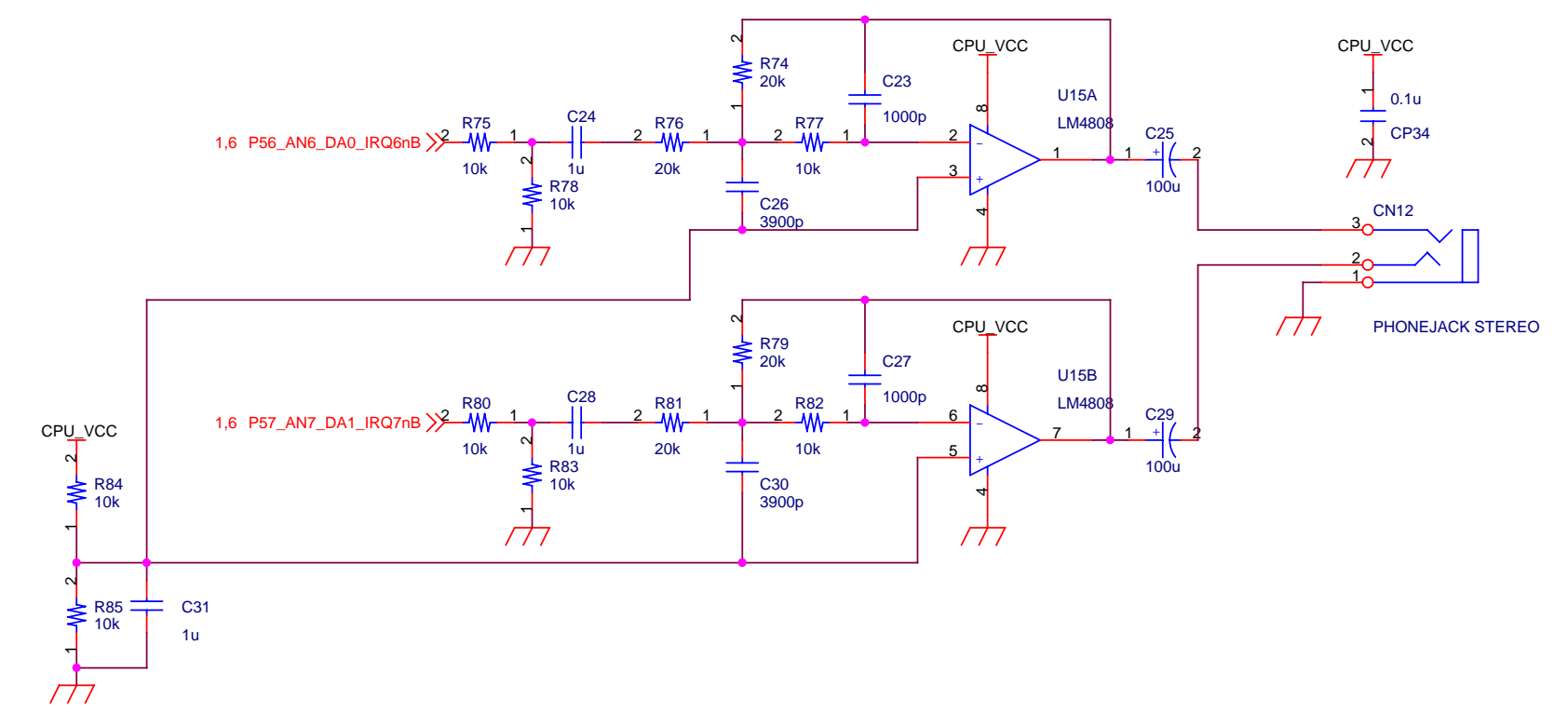
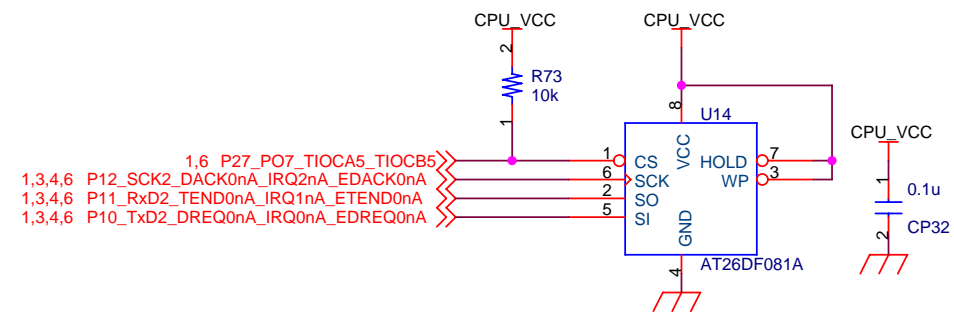

Title		
R0K51668R001BR		
Size	Document Number	Rev
A3	SW, E10A, Reset, SD, Power	3.0
Date:	Monday, February 23, 2009	Sheet 5 of 6

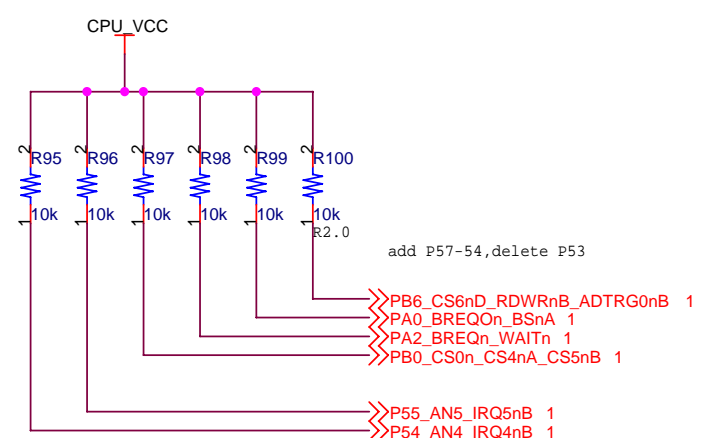
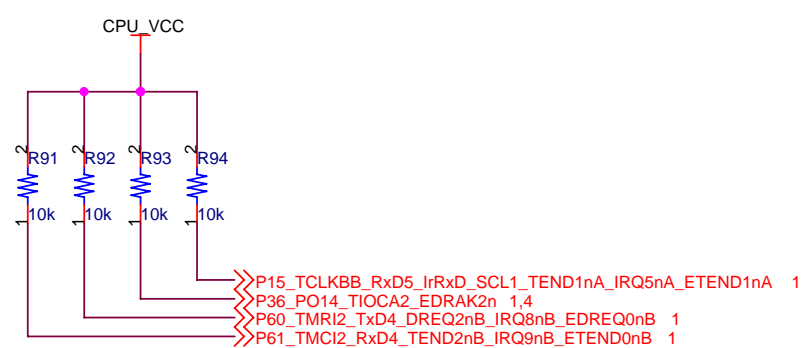
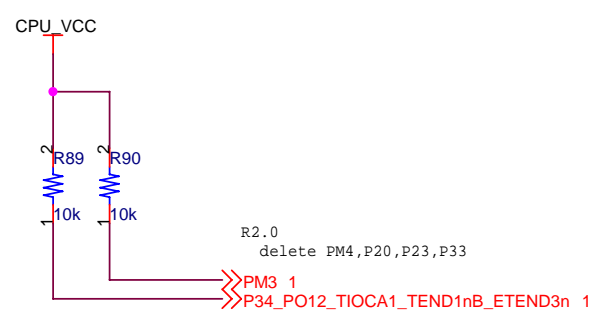
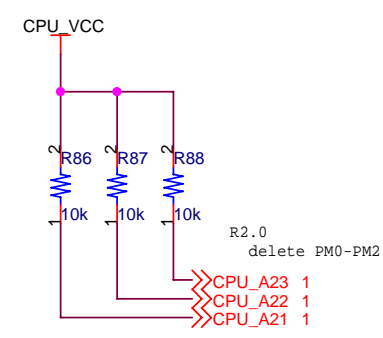
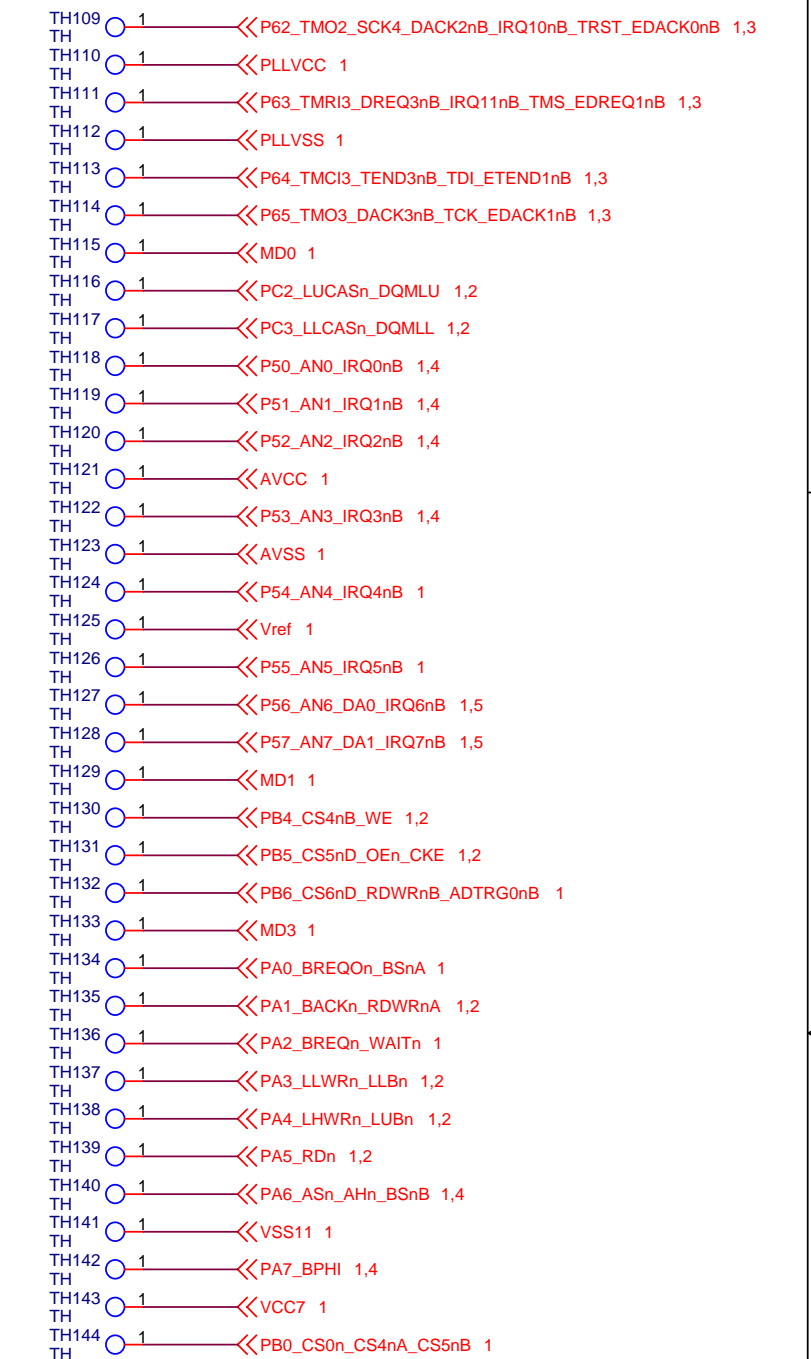
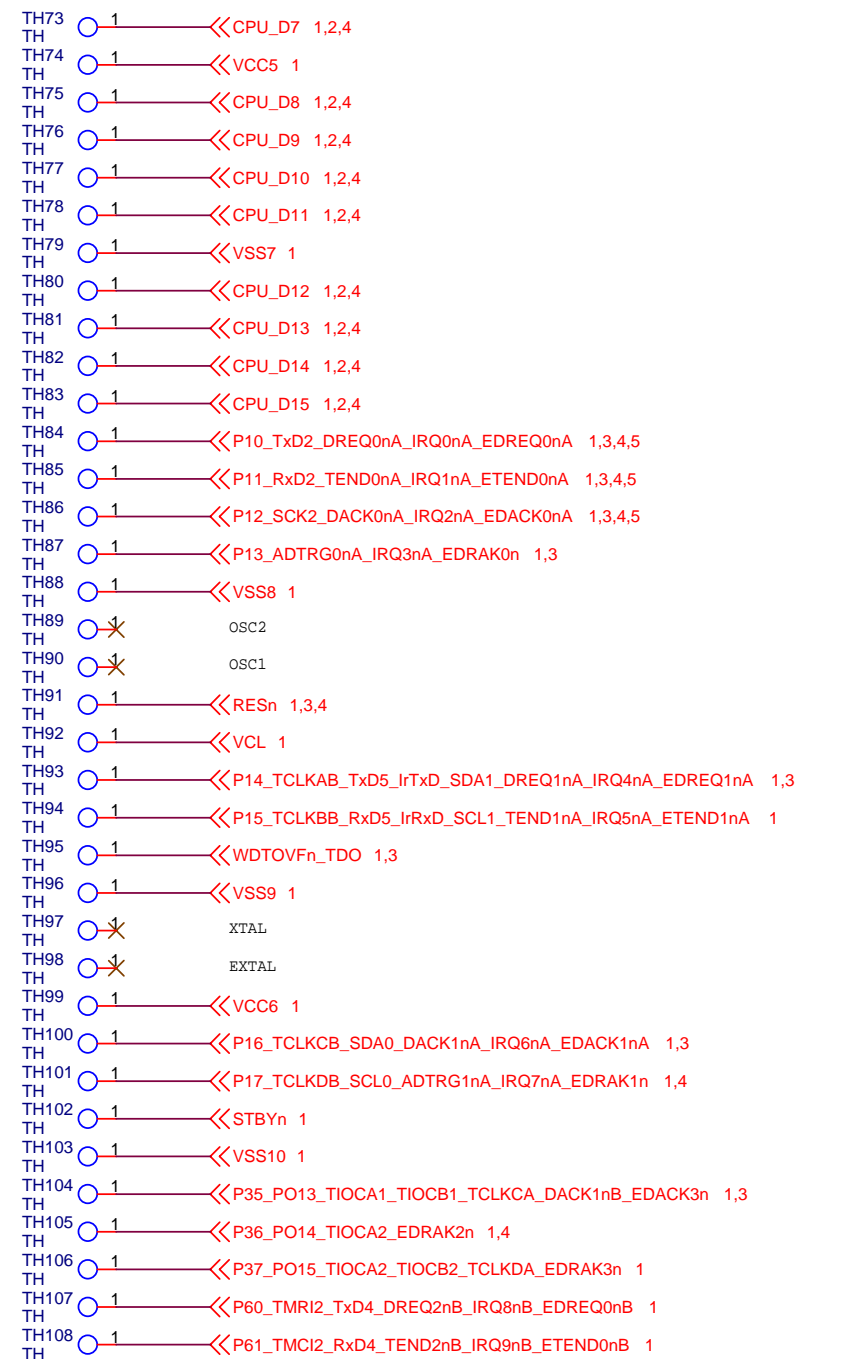
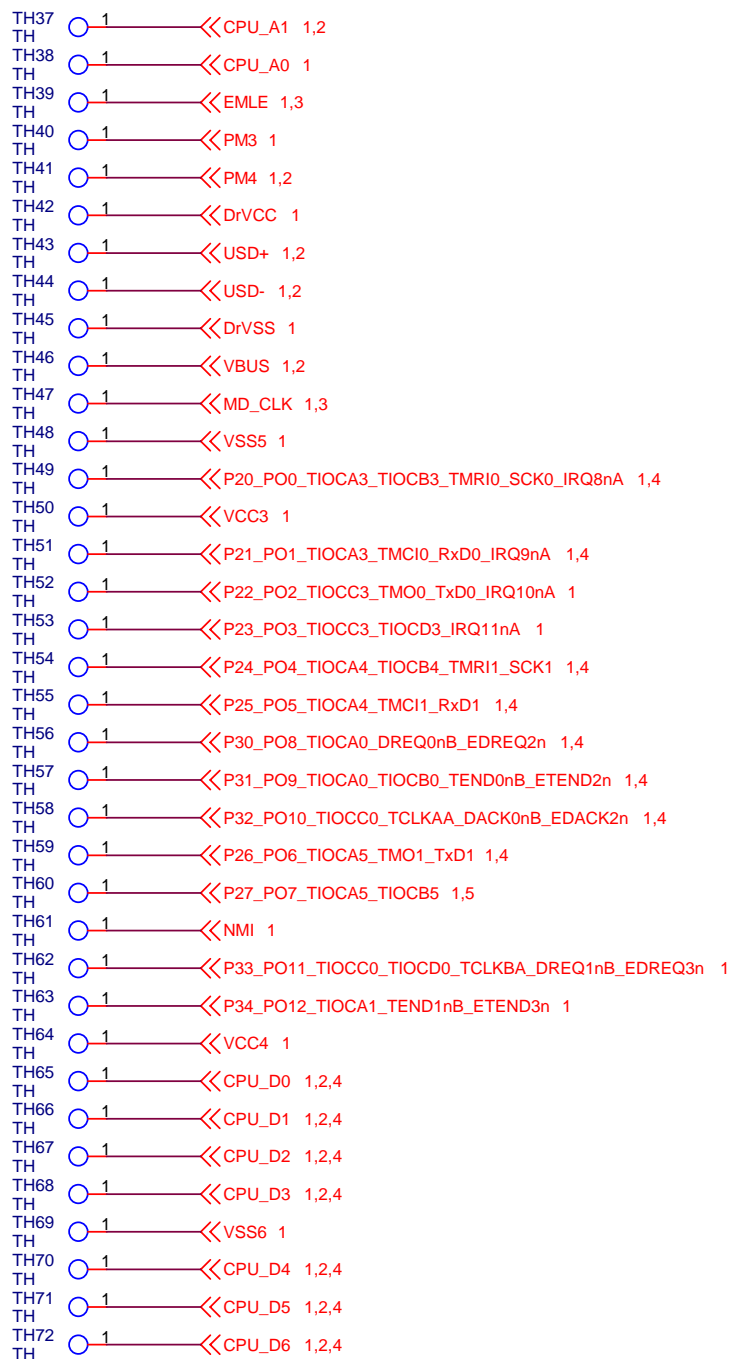
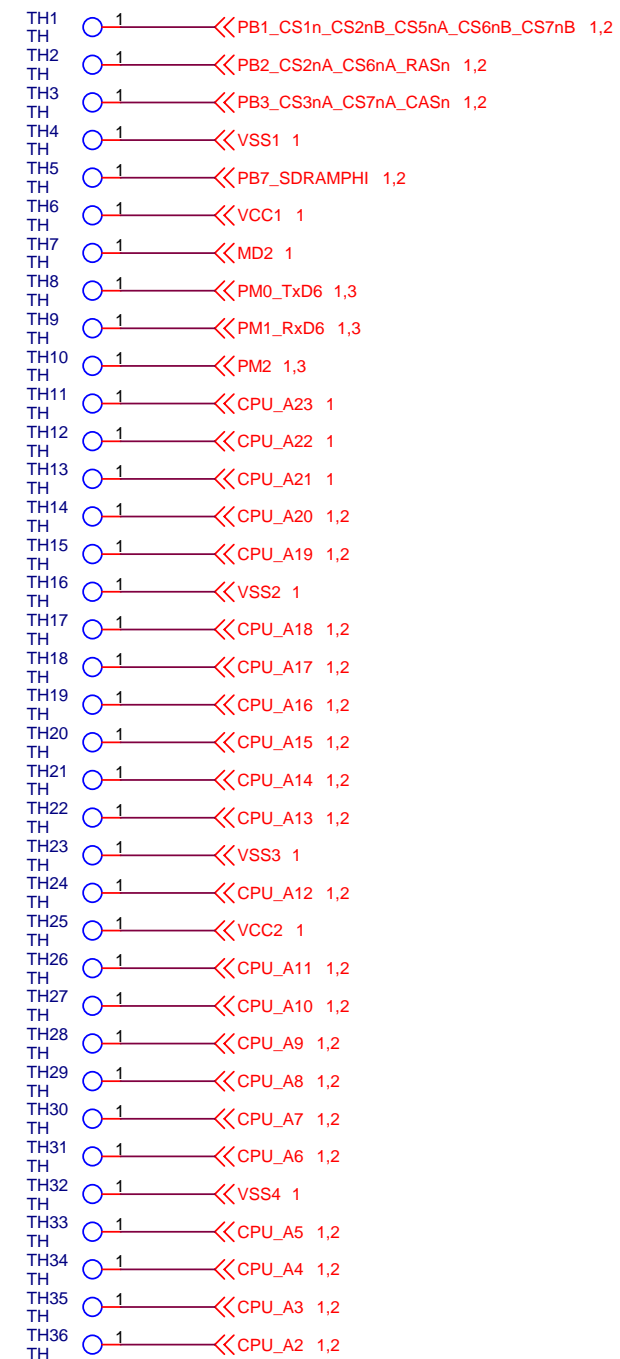

Title		
R0K51668R001BR		
Size	Document Number	Rev
A3	TH	3.0
Date:	Monday, February 23, 2009	Sheet 6 of 6