

REV	REF	DATE	DRAWN BY
1	---	14.01.2009	SHN
2	TRAC#1265	26.03.2009	SHN
3	ECR#198	07.07.2009	SHN
4	TRAC#1359	25.08.2009	SHN

# RSK2H8S2456R STARTER KIT SCHEMATICS

PAGE	DESCRIPTION
1	Index
2	Microcontroller-1
3	Microcontroller-2
4	Memory
5	Address and Data Bus Buffer
6	Switches, Power Supply and Reset
7	E10A Debug Connector and Serial Port
8	Application Headers
9	Ring Connectors
10	Generic LCD Connector and USB

**Note :**

- R** : Resistor
- RV** : Potentiometer
- L** : Inductor
- U** : Integrated Circuit
- X** : Crystal
- RES** : Reset Switch
- SW** : Switch
- LED** : Light Emitting Diode
- PWR** : Power Jack
- J** : Connector

SIZE A4

<b>RENESAS TECHNOLOGY EUROPE LTD</b> Dukes Meadow, Bourne End, Buckinghamshire UNITED KINGDOM				
SCHEMATIC TITLE <b>RSK2H8S2456R</b>				
SHEET TITLE <b>Index</b>				
DRAWN BY SHN	DATE 25-08-09	REV 4	DRAWING NUMBER D008672_04	PAGE 1/10

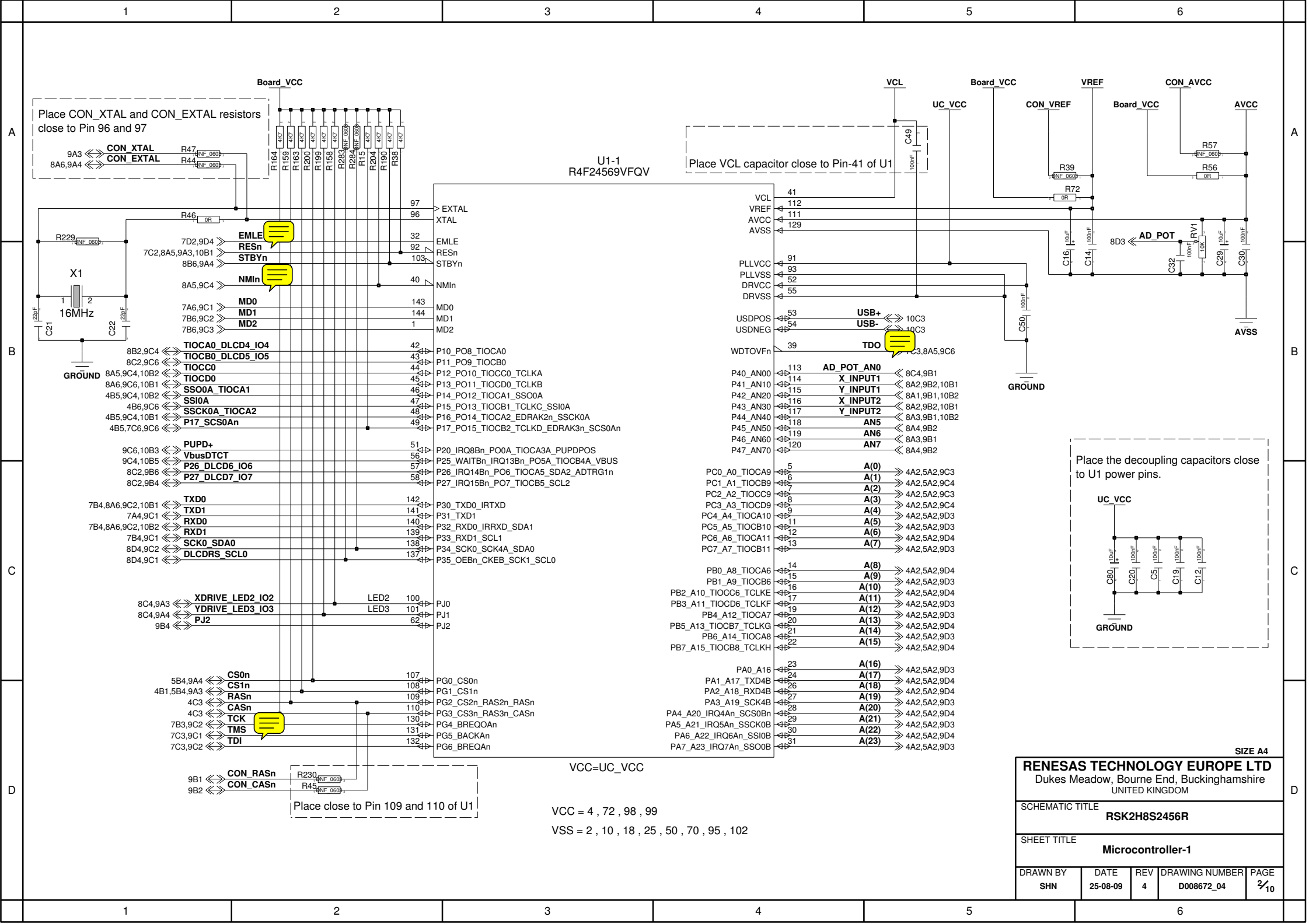

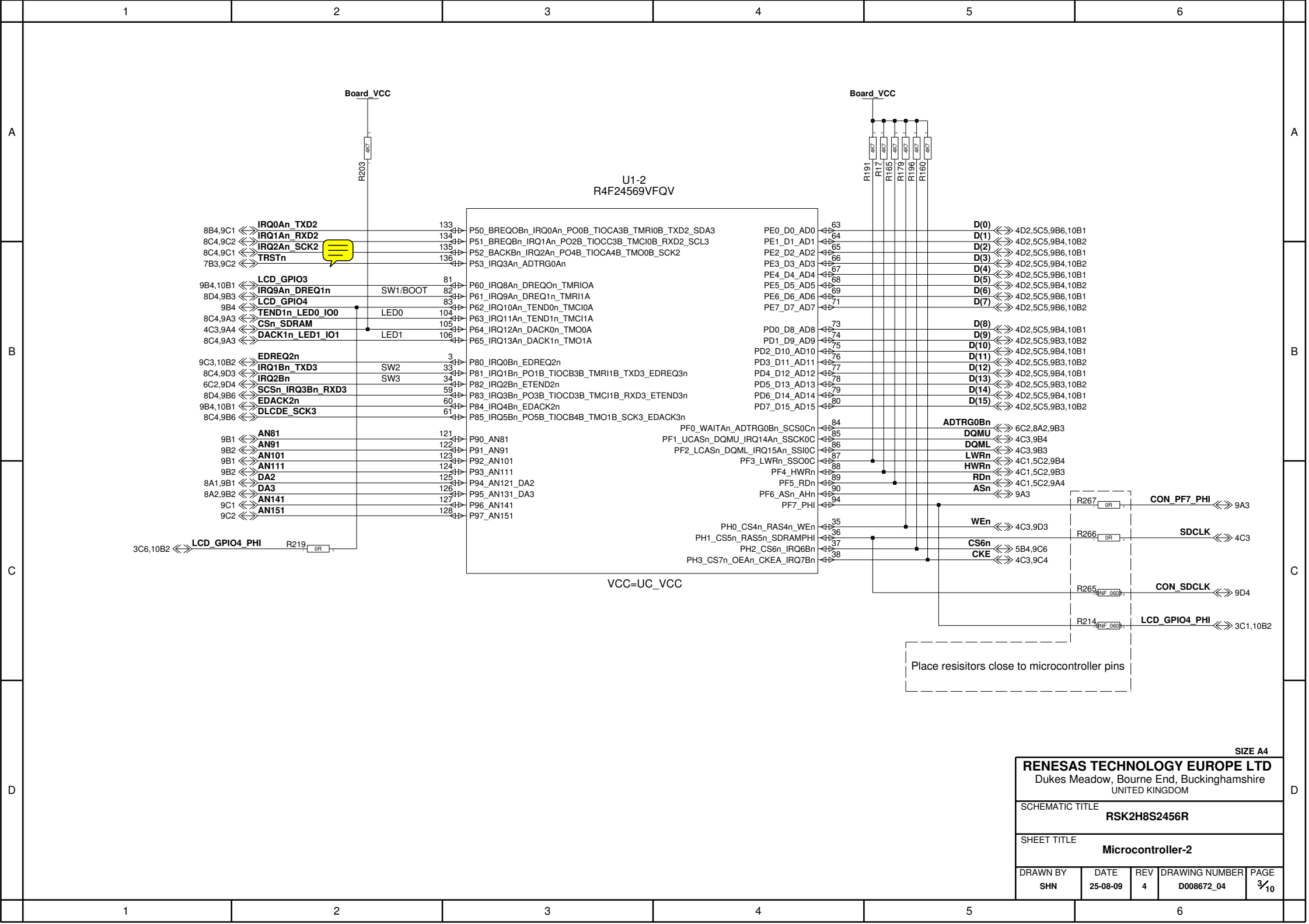

U1-2  
R4F24569VFQV

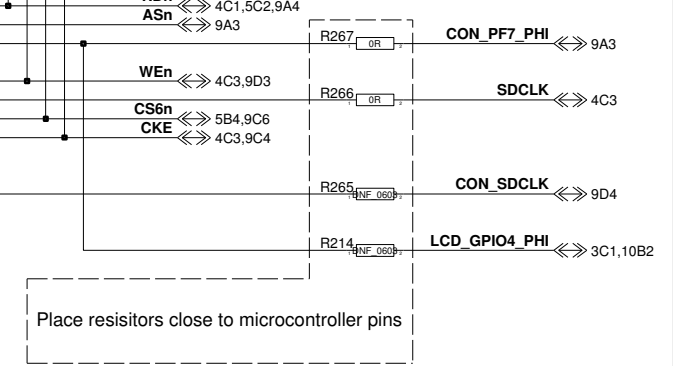
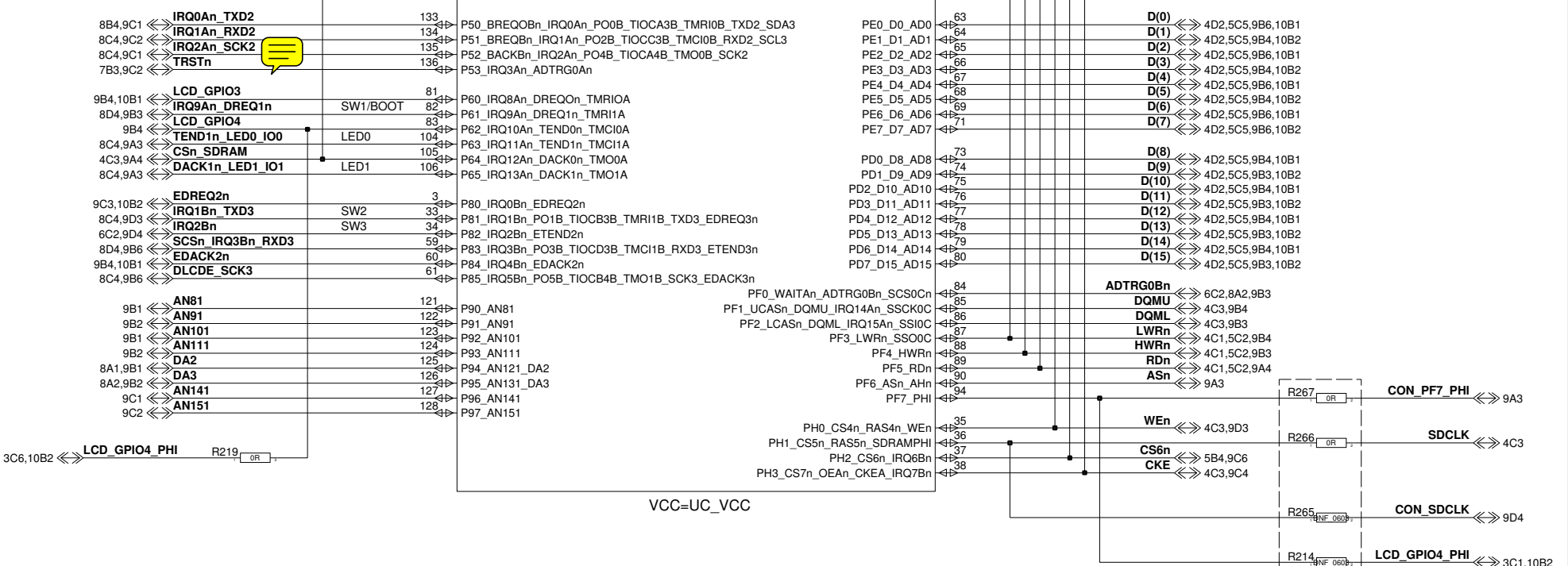

SIZE A4

**RENESAS TECHNOLOGY EUROPE LTD**  
Dukes Meadow, Bourne End, Buckinghamshire  
UNITED KINGDOM

SCHEMATIC TITLE  
**RSK2H8S2456R**

SHEET TITLE  
**Microcontroller-2**

DRAWN BY SHN	DATE 25-08-09	REV 4	DRAWING NUMBER D008672_04	PAGE 3/10
-----------------	------------------	----------	------------------------------	--------------

**SRAM (16Mbit)  
SDRAM (64Mbit)**

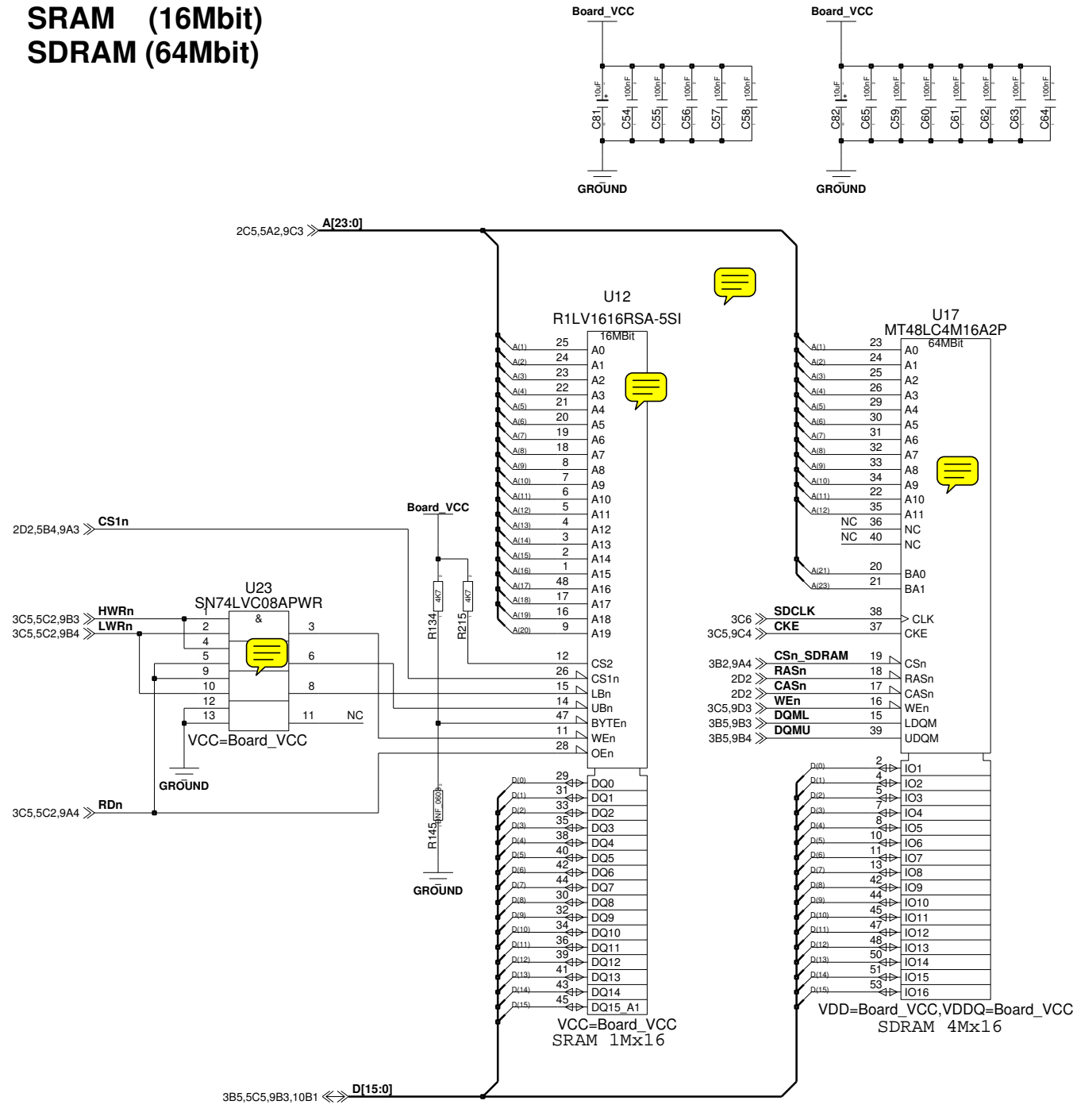

**16 Mbit SPI Serial Flash**

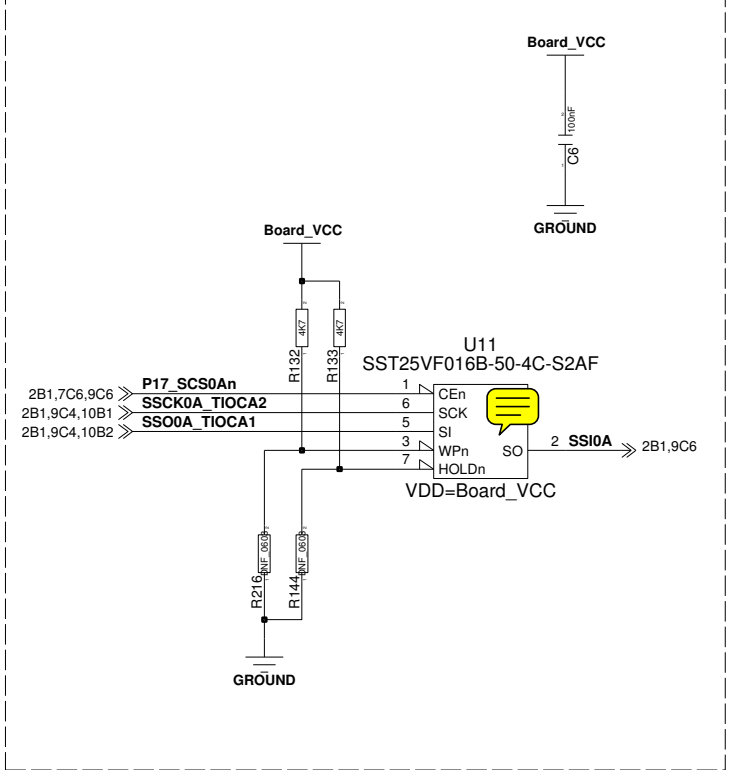

SIZE A4

<b>RENESAS TECHNOLOGY EUROPE LTD</b> Dukes Meadow, Bourne End, Buckinghamshire UNITED KINGDOM				
SCHEMATIC TITLE <b>RSK2H8S2456R</b>				
SHEET TITLE <b>Memory</b>				
DRAWN BY SHN	DATE 25-08-09	REV 4	DRAWING NUMBER D008672_04	PAGE 4/10

## Expansion Address Bus and Control Signal Buffer

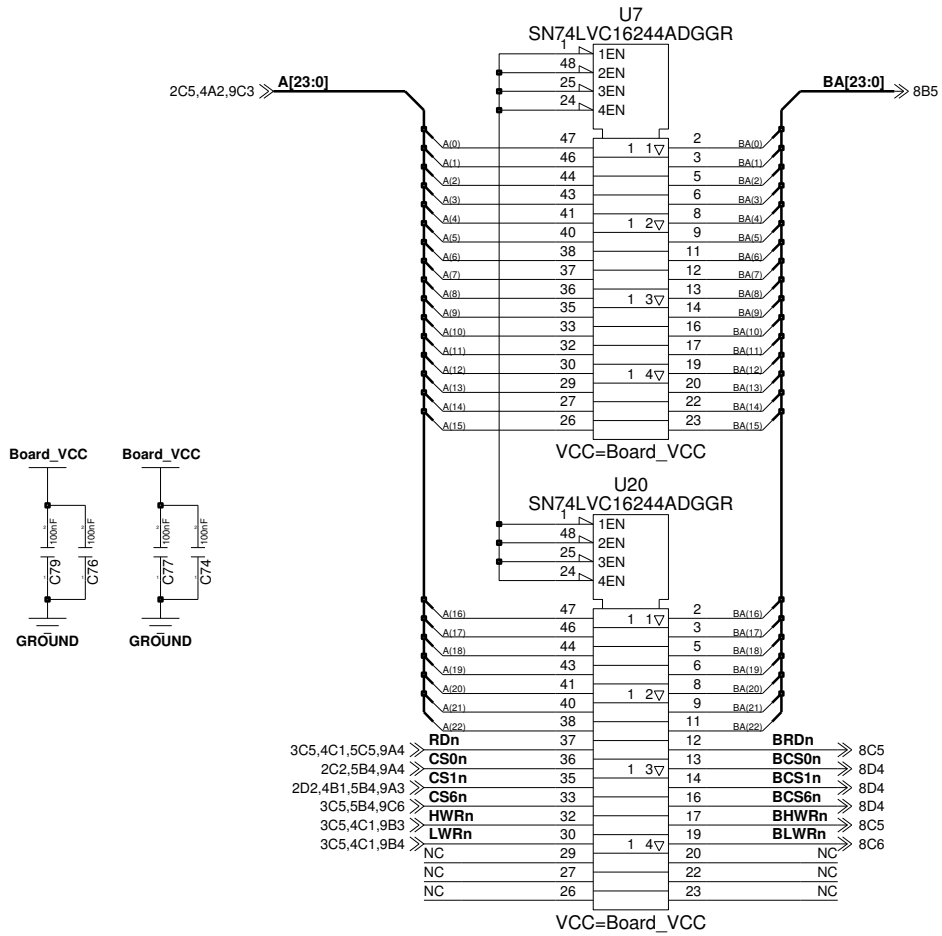

## Data Bus Direction selector and Buffer

RDn	U6
0	External Address space is being read
1	External Address space is being written

Area	Interface
CS0	Expansion Header (JA3)
CS1	SRAM
CS6	Expansion Header (JA3)
CSn_SDRAM	SDRAM

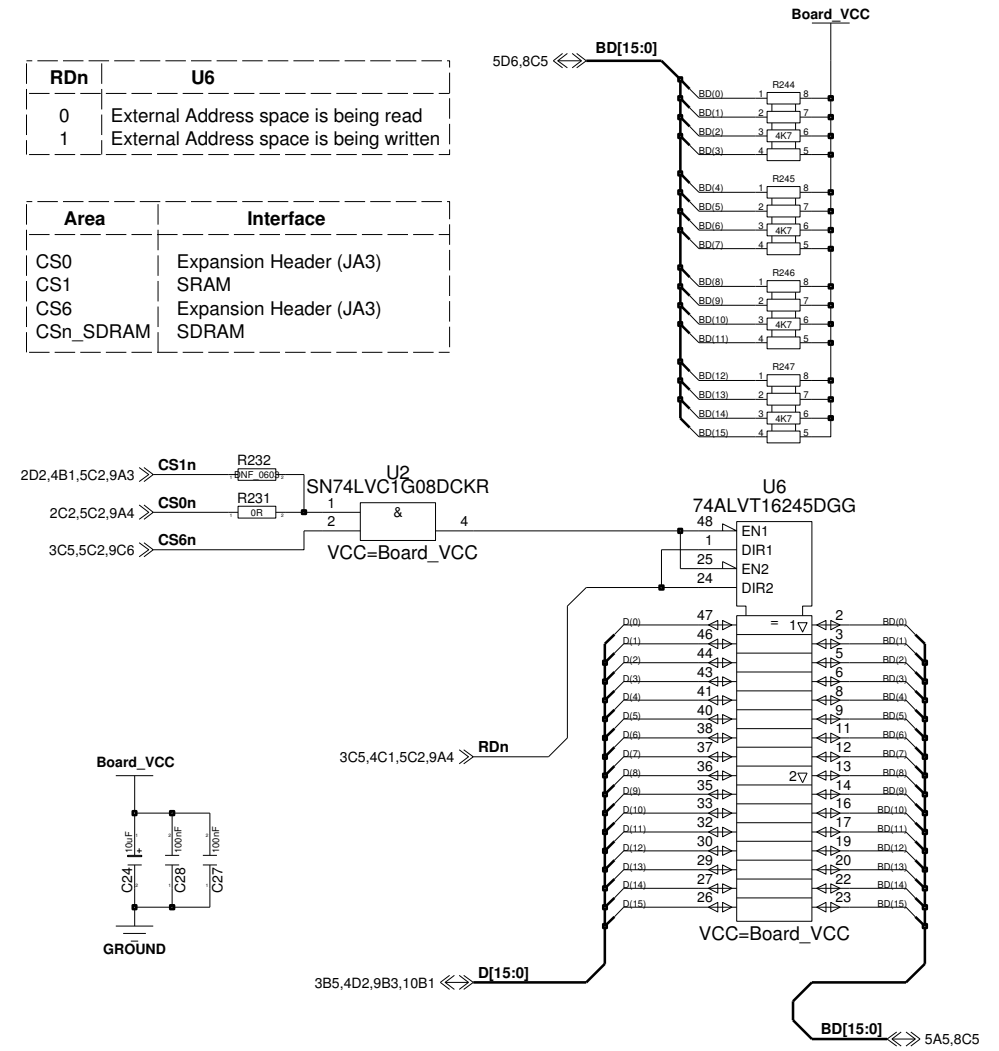

SIZE A4

RENESAS TECHNOLOGY EUROPE LTD  
Dukes Meadow, Bourne End, Buckinghamshire  
UNITED KINGDOM

SCHEMATIC TITLE  
**RSK2H8S2456R**

SHEET TITLE  
**Address and Data Bus Buffer**

DRAWN BY	DATE	REV	DRAWING NUMBER	PAGE
SHN	25-08-09	4	D008672_04	5/10

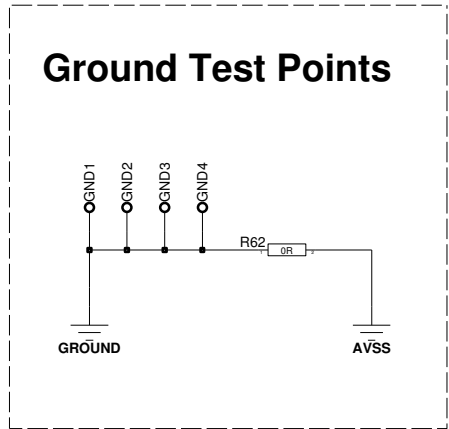
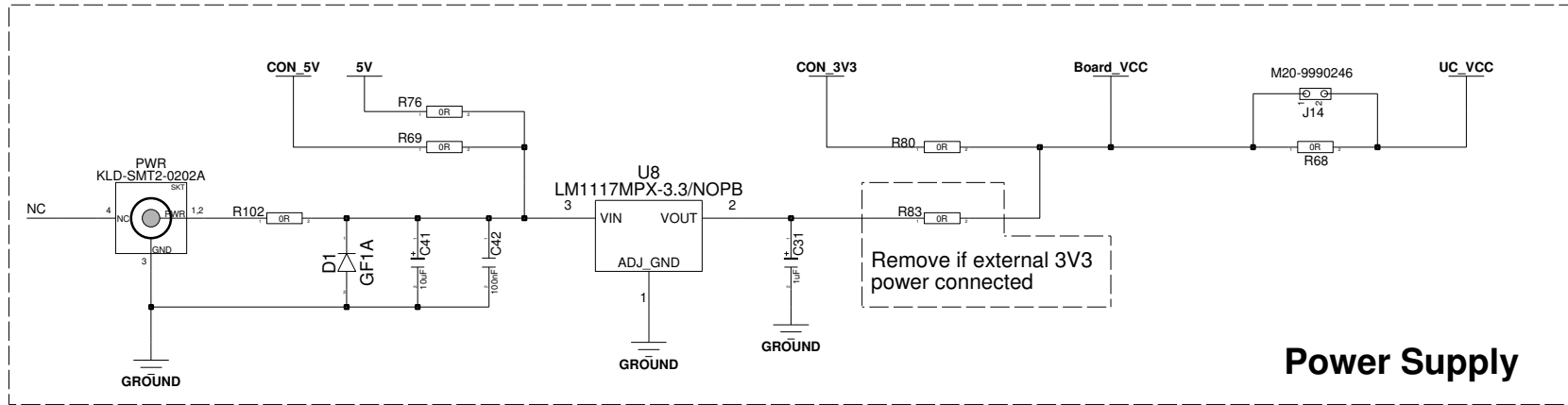

### Power Supply

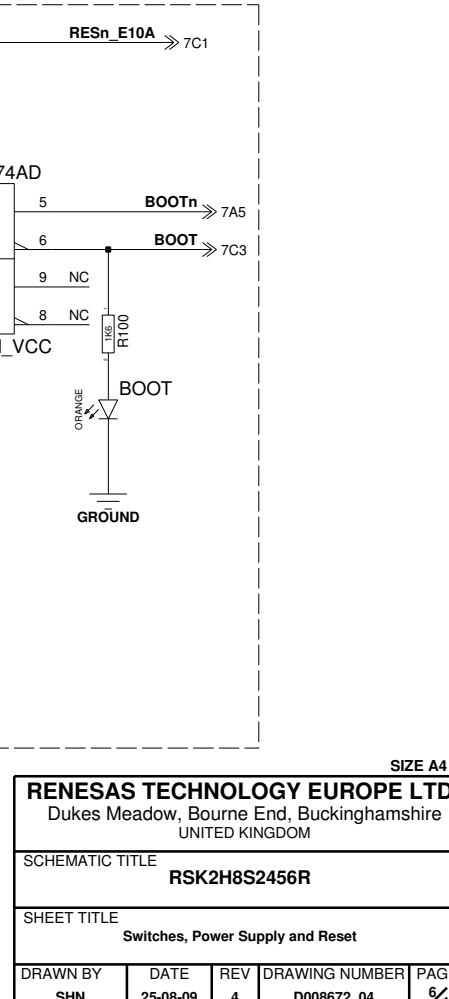
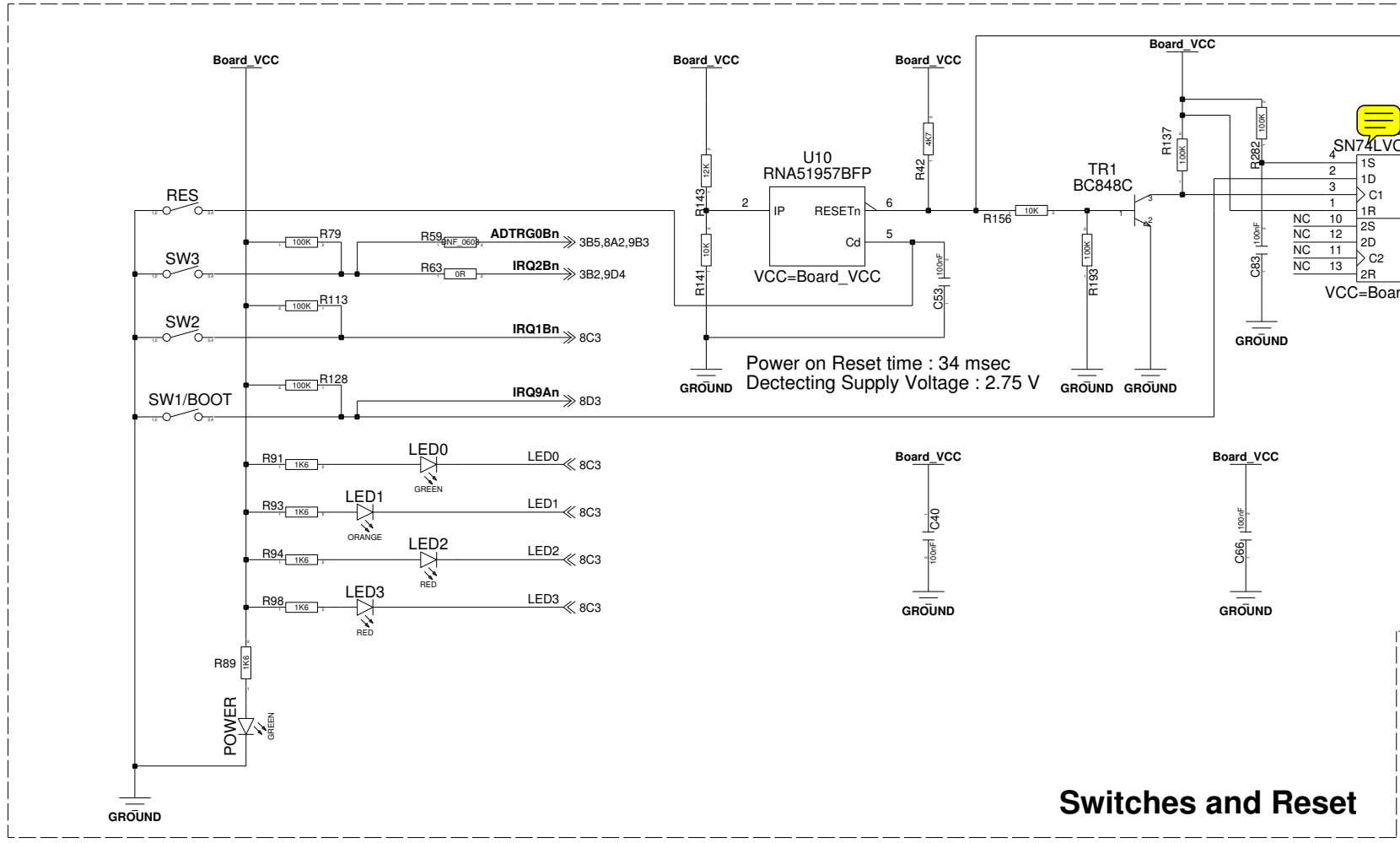

### Switches and Reset

SIZE A4

**RENESAS TECHNOLOGY EUROPE LTD**  
 Dukes Meadow, Bourne End, Buckinghamshire  
 UNITED KINGDOM

SCHEMATIC TITLE  
**RSK2H8S2456R**

SHEET TITLE  
 Switches, Power Supply and Reset

DRAWN BY SHN	DATE 25-08-09	REV 4	DRAWING NUMBER D008672_04	PAGE 6/10
-----------------	------------------	----------	------------------------------	--------------







# Generic TFT LCD Header

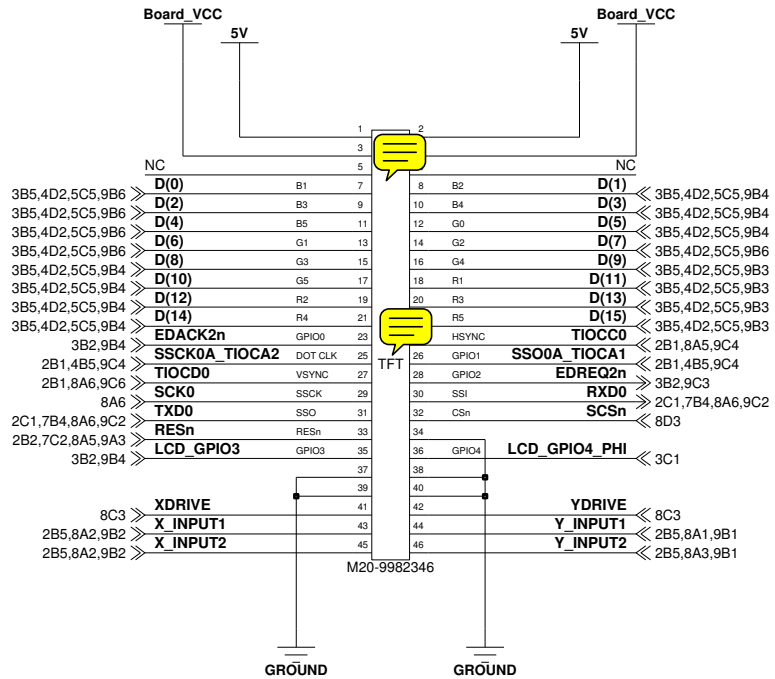

# USB Function

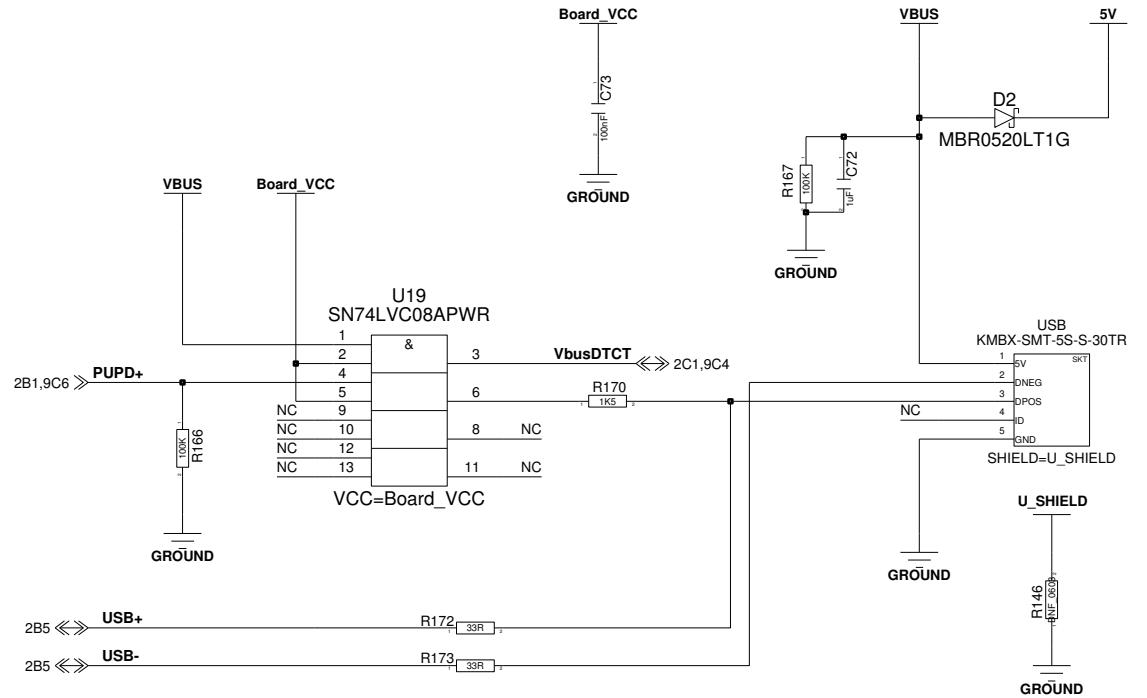

USB signals should have matched lengths.

SIZE A4				
<b>RENESAS TECHNOLOGY EUROPE LTD</b> Dukes Meadow, Bourne End, Buckinghamshire UNITED KINGDOM				
SCHEMATIC TITLE <b>RSK2H8S2456R</b>				
SHEET TITLE <b>Generic LCD Connector and USB</b>				
DRAWN BY SHN	DATE 25-08-09	REV 4	DRAWING NUMBER D008672_04	PAGE 1/10