

REV	REF	DATE	DRAWN BY
1	---	07.07.2006	DDE
2	ECO 818	05.09.2006	DDE

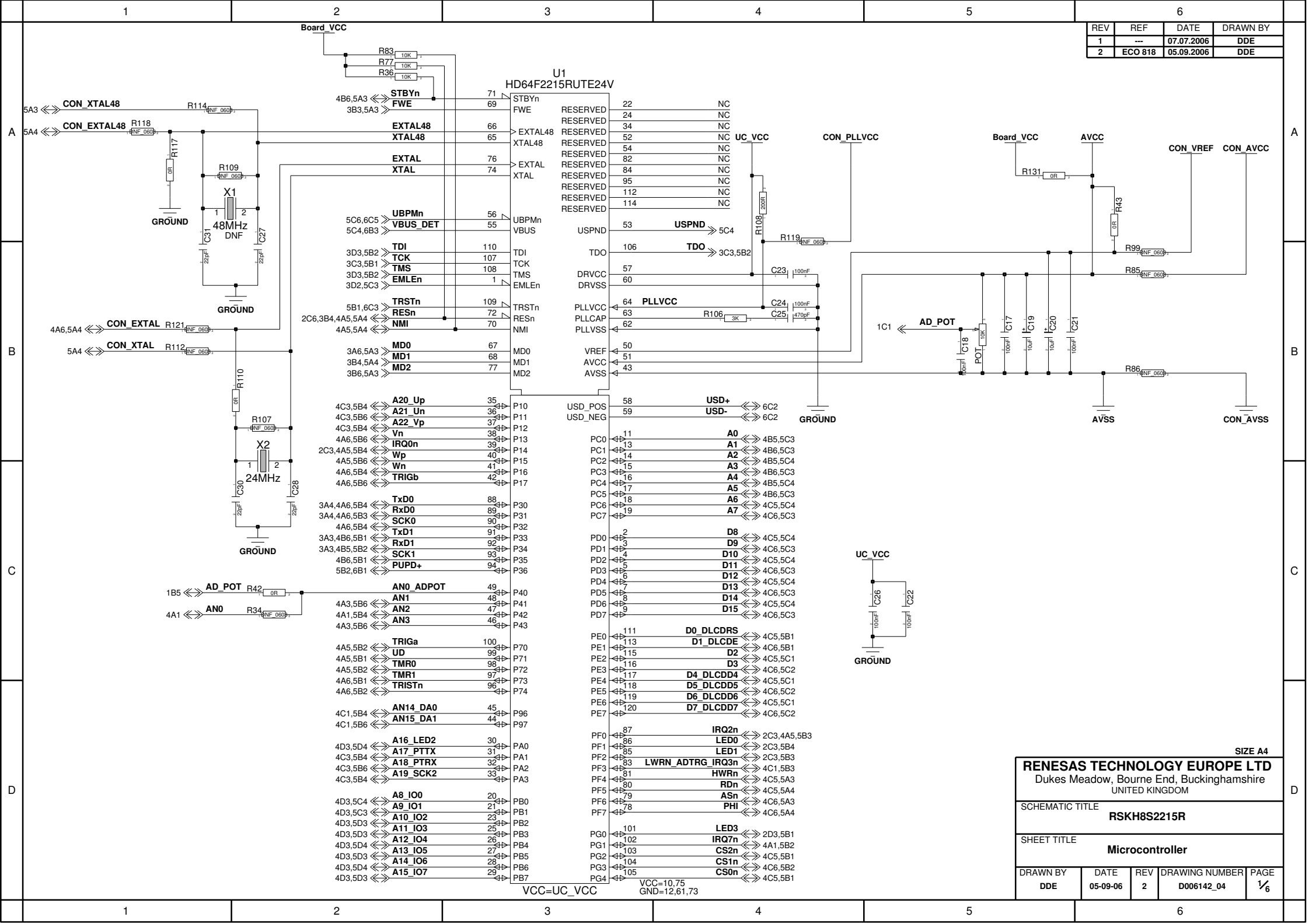

SIZE A4

**RENESAS TECHNOLOGY EUROPE LTD**  
 Dukess Meadow, Bourne End, Buckinghamshire  
 UNITED KINGDOM

SCHEMATIC TITLE  
**RSKH8S2215R**

SHEET TITLE  
**Microcontroller**

DRAWN BY DDE	DATE 05-09-06	REV 2	DRAWING NUMBER D006142_04	PAGE 1/6
-----------------	------------------	----------	------------------------------	-------------

VCC=UC\_VCC  
 GND=12,61,73



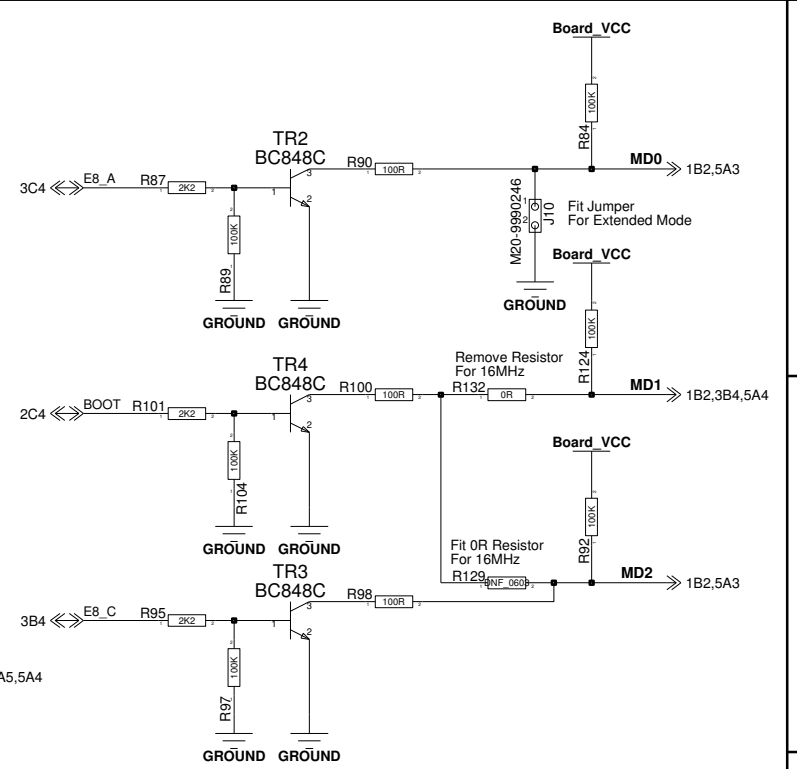
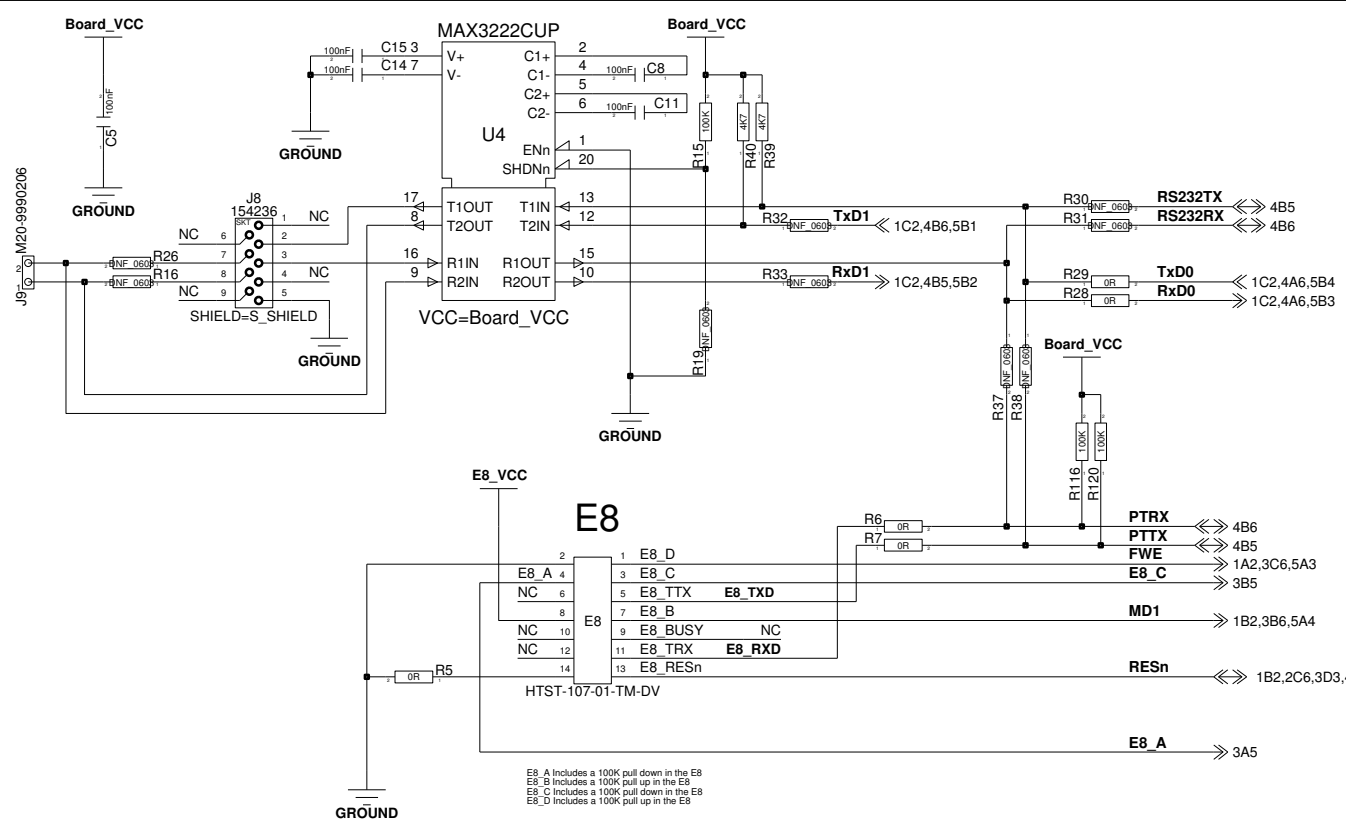

E8\_A Includes a 100K pull down in the E8  
 E8\_B Includes a 100K pull up in the E8  
 E8\_C Includes a 100K pull down in the E8  
 E8\_D Includes a 100K pull up in the E8

MD2	MD1	MD0	Mode
0	1	0	16MHz Boot Extended Mode. Select using MD0 Jumper.
0	1	1	16MHz Boot Single Chip Mode. Select using MD0 Jumper.
1	0	0	24MHz Boot Extended Mode. Select using MD0 Jumper.
1	0	1	24MHz Boot Single Chip Mode. Select using MD0 Jumper.
1	1	0	Extended Mode.
1	1	1	Single Chip Mode (Default).

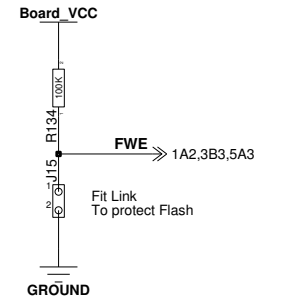
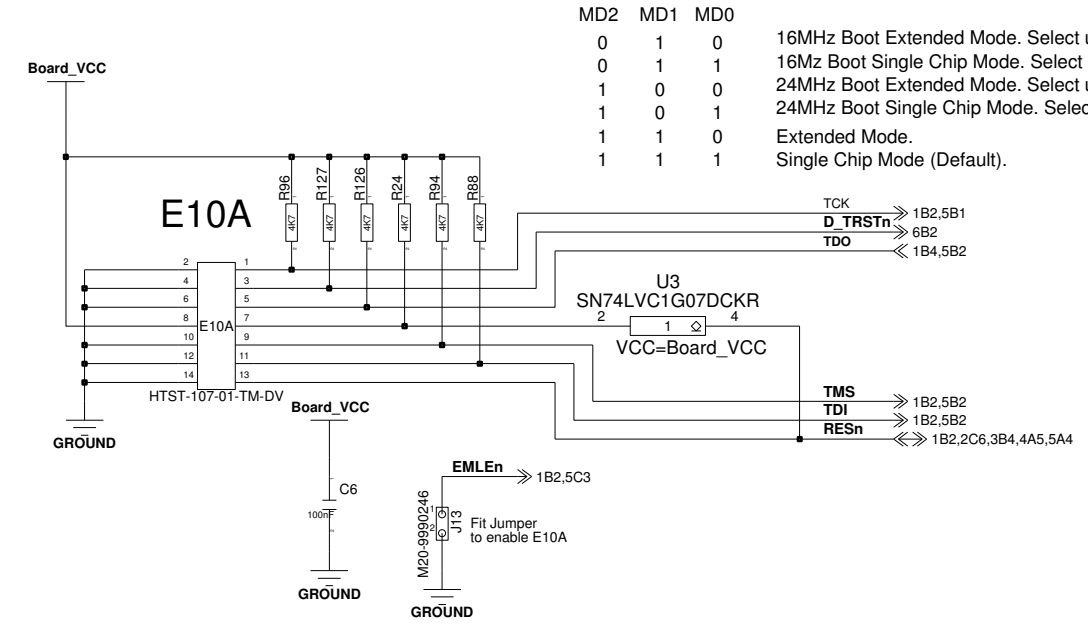

SIZE A4

**RENESAS TECHNOLOGY EUROPE LTD**  
 Dukes Meadow, Bourne End, Buckinghamshire  
 UNITED KINGDOM

SCHEMATIC TITLE  
**RSKH8S2215R**

SHEET TITLE  
**E8 & E10A Debug connectors & Serial Port**

DRAWN BY DDE	DATE 05-09-06	REV 2	DRAWING NUMBER D006142_04	PAGE 3/6
-----------------	------------------	----------	------------------------------	-------------

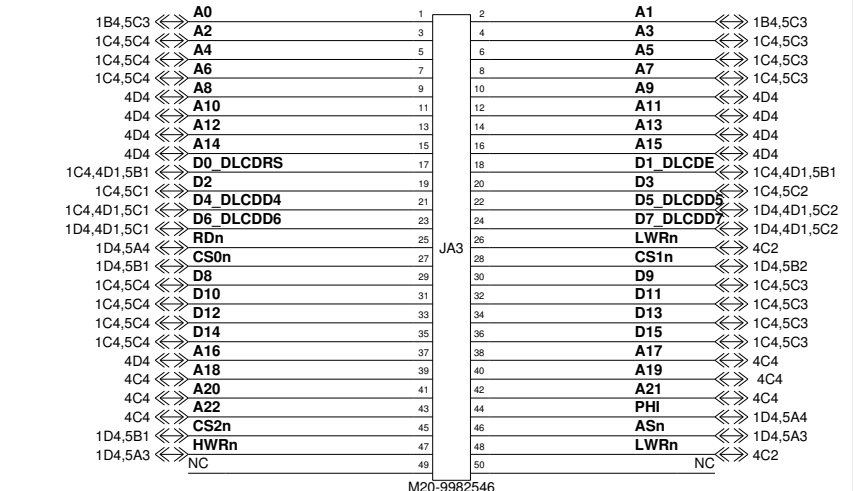
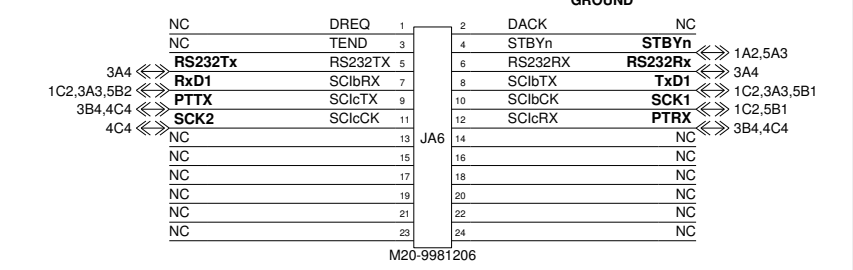
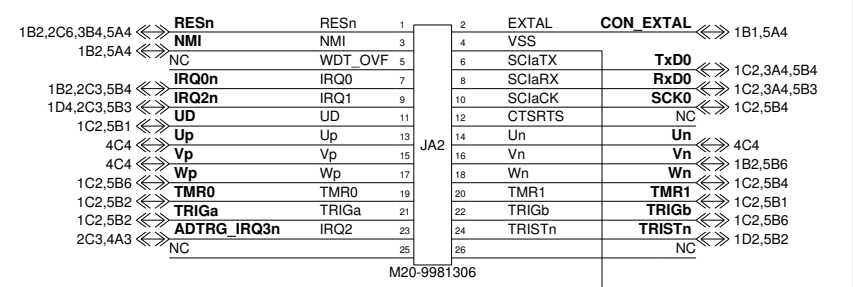
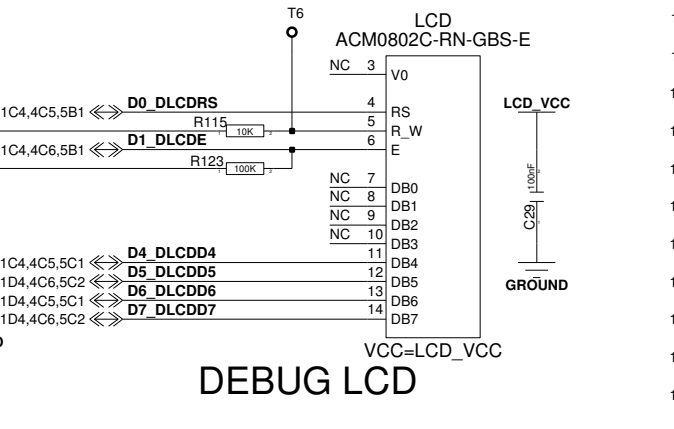
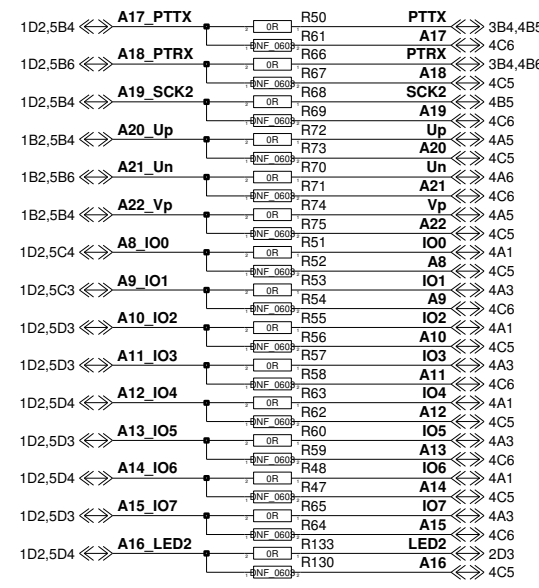
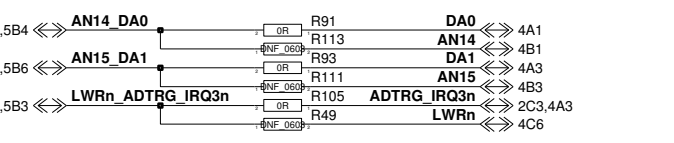
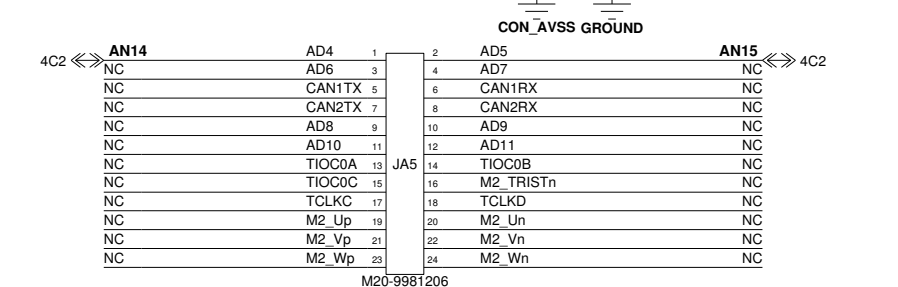
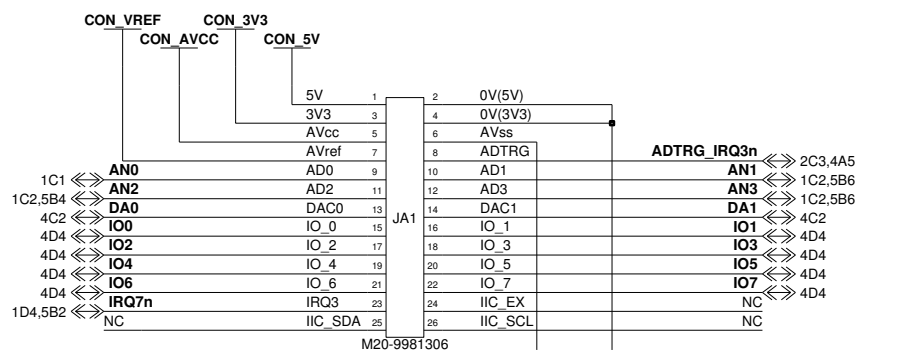

SIZE A4

**RENESAS TECHNOLOGY EUROPE LTD**  
 Dukas Meadow, Bourne End, Buckinghamshire  
 UNITED KINGDOM

SCHEMATIC TITLE  
**RSKH8S2215R**

SHEET TITLE  
 Application Headers

DRAWN BY DDE	DATE 05-09-06	REV 2	DRAWING NUMBER D006142_04	PAGE 4/6
-----------------	------------------	----------	------------------------------	-------------



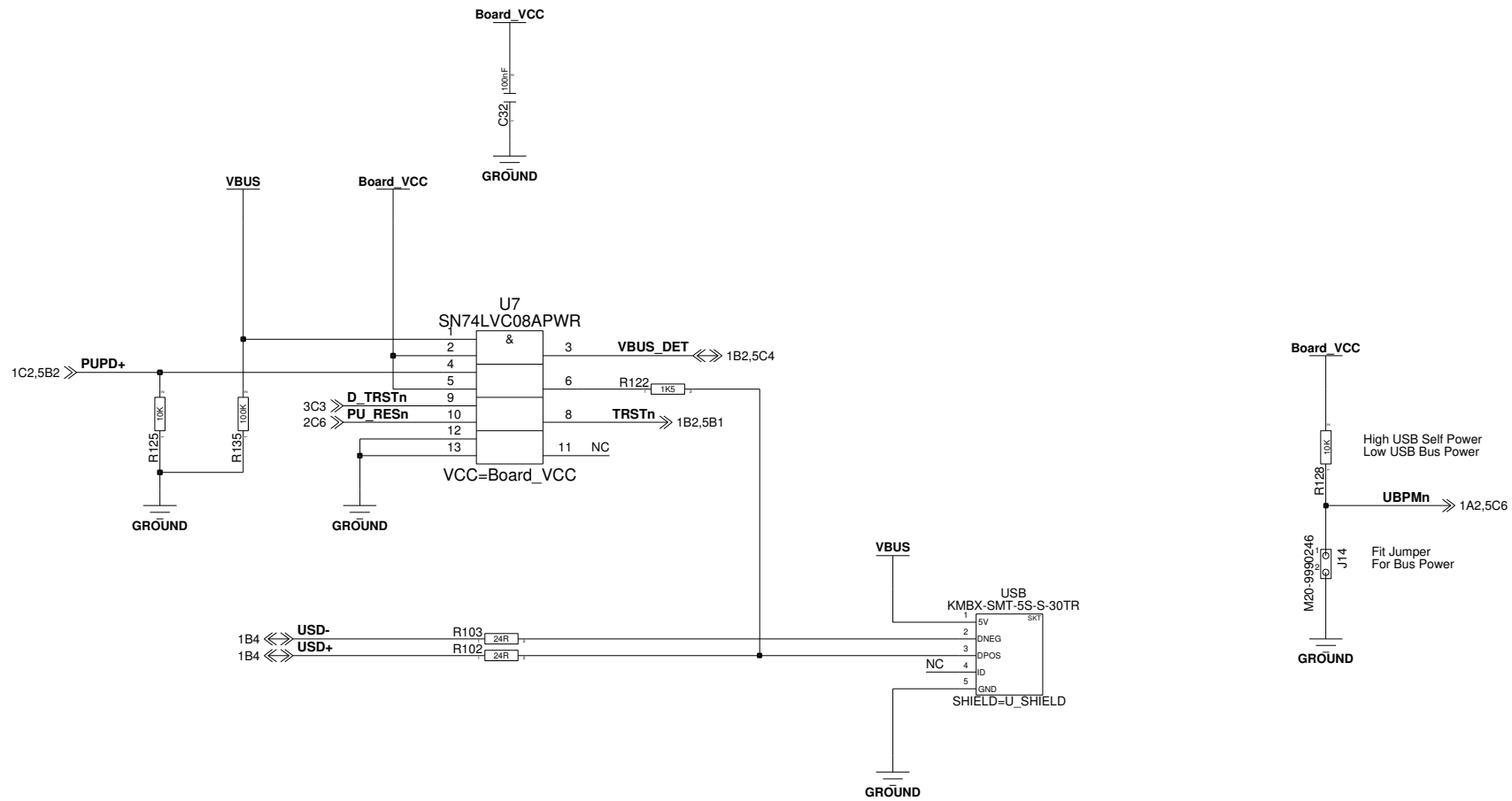

SIZE A4

<b>RENESAS TECHNOLOGY EUROPE LTD</b> Dukes Meadow, Bourne End, Buckinghamshire UNITED KINGDOM				
SCHEMATIC TITLE <b>RSKH8S2215R</b>				
SHEET TITLE <b>USB</b>				
DRAWN BY DDE	DATE 05-09-06	REV 2	DRAWING NUMBER D006142_04	PAGE 6/6