



Overview

Flat panel TV (LCD TV) have grown rapidly in popularity due to increasing availability of digital services and high definition digital media content. Since the TV in the home is a product that is typically in use for several hours every day, it is required to be increasing more energy efficient and eco-friendly. Advanced functionality, such as a CEC link functionality using a HDMI (High-Definition Multimedia Interface) connection is now a common requirement for LCD TVs.

Renesas supplies effective solutions for customers developing eco-friendly home electronic products, such as the 78K0, 78K0R Series, R8C Family and M16C Family of energy-efficient MCUs. These MCUs deliver functionality, such as support for CEC which receives commands from a remote control while in system standby mode, while also maintaining a low level of power consumption. Renesas also offers a wide lineup of devices, such as audio and video processors, that are essential in the development of multimedia AV products.

System Block Diagram

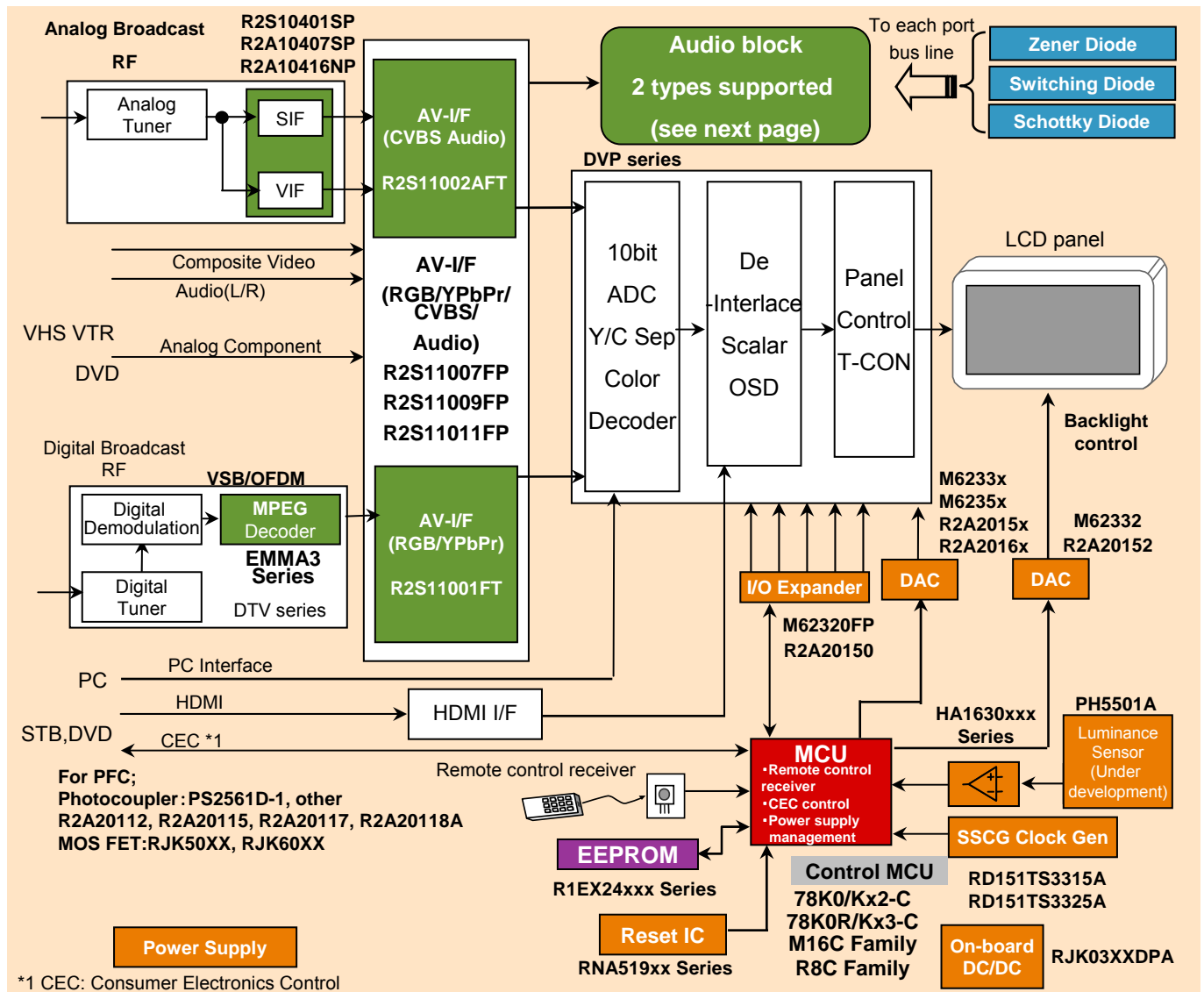

■Audio Block

Digital Solution

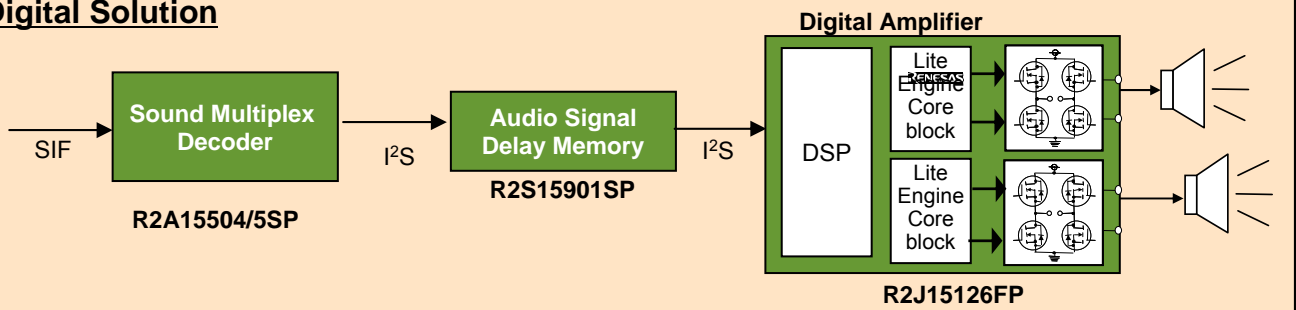

Analog Solution

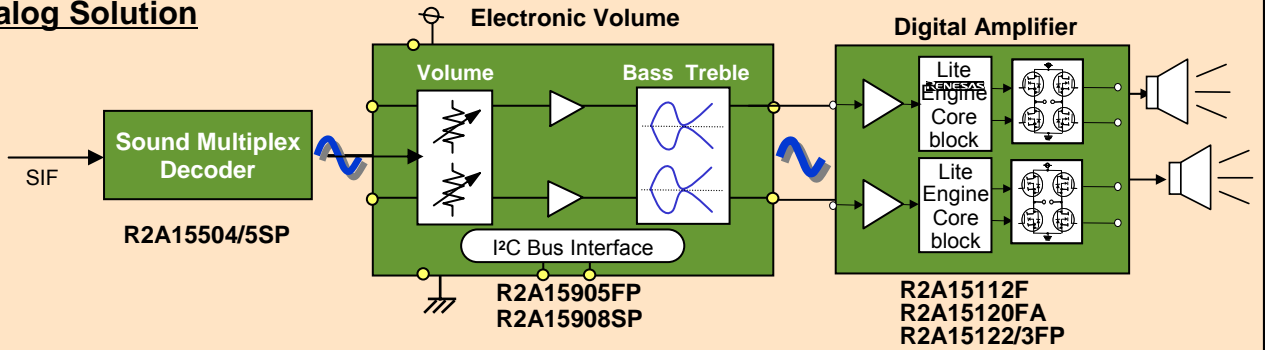

■Tuner Block

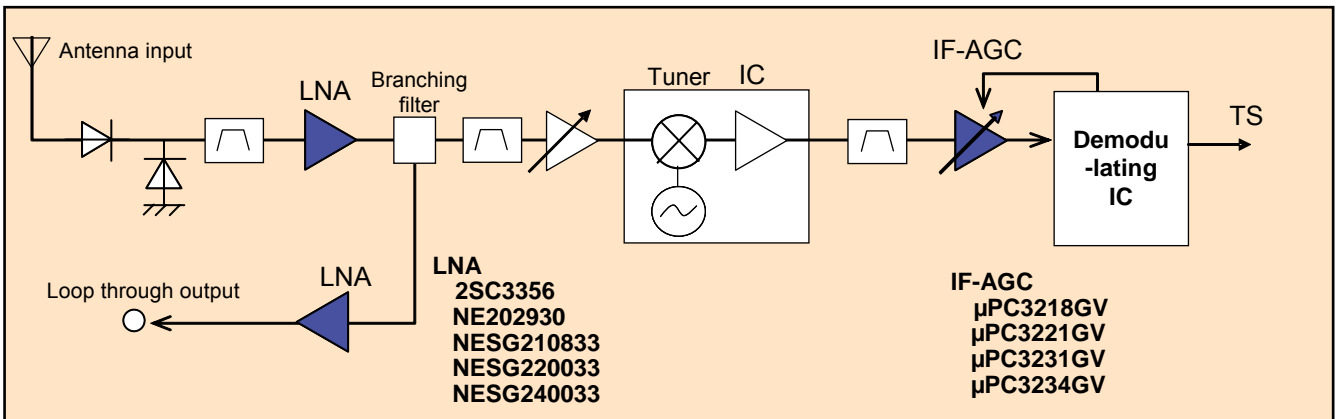

Recommended Products

As of July 2010

Block	Semiconductor device	Recommended products	Features, etc.
Power supply section	PFC power supply control IC	R2A20112, R2A20117, R2A20118A	Continuous conduction mode single
		R2A20115	Critical conduction mode interleaving
	Power MOSFET	2SK31xxB, 2SK32xxB, 2SK33xxB	500 V, 600 V tolerance
		RJK60xxDxx, RJK50xxDxx	500 V, 600 V tolerance
Photocoupler (Standard)	PS25xx Series PS27xx Series PS28xx Series	High isolation voltage(5kVr.m.s.), 4p-DIP High isolation voltage(3.75kVr.m.s.), 4p-SOP High isolation voltage,(2.5kVr.m.s.), 4p-SSOP	
LCD panel	D/A converter for image adjustment	M6233x Series, M6235x Series R2A2015x Series, R2A2016x Series	I2C supported, 2 to 4 channels, 8 pins; 3-line type 6 to 12 channels *1
	Image adjustment (dimmer) D/A converter	R2A20152, M62332	I2C supported, 2 channels *1
Video	MPEG Decoder	EMMA3 Series	
Audio	Sound multiplex decoder	R2A15504/5SP	
	Digital delay	R2S15901SP	
	Audio signal processor	R2A15905FP	Built-in HP (headphone) amplifier
		R2A15908SP	
	Digital amp	R2A15112FP	15 W x 2 ch: Single End
		R2A15126FP *	
R2A15120FA		15 W x 2 ch: BTL (built-in limiter)	
	R2A15122/3FP	10 W x 2 ch (4 W x 2 ch): Single End	
Main controller	CPU	78K0/Kx2-C	Low power consumption, CEC function
		78K0R/Kx3-C	
		R8C Family, M16C Family	
	I/O expander	R2A20150, M62320	I2C supported, 8-bit I/O *1
	Reset IC	RNA519xx Series	Variable detection voltage and delay time
	CMOS op-amp.	HA1630xxx Series	Low power consumption
	Analog switch	R2S11001FT	
		R2S11002AFT	
		R2S11007FP	
		R2S11009FP	
		R2S11011FP	
	VIF/SIF signal processor	R2S10401SP	
		R2S10407SP	
		R2S10416NP	
	MOS FET for On-board DC/DC	RJK03xxDPA	30 V tolerance, WPAK
UPA27xxT1A		30 V tolerance, HVSON	
Clock generator	RD151TS3315A		
	RD151TS3325A		
EEPROM	R1EX24xxx Series	I2C bus Interface *1	
	R1EX25xxx Series	SPI bus Interface *2	
Luminance Sensor	PH5501A	illuminance level 1~10,000lx, analog linear output	

- > Continues to the next page

Recommended Products

As of July 2010

Block	Semiconductor device	Recommended products	Features, etc.
General use, surge absorption, circuit protection, etc.	Zener Diodes	HZM6.2ZMWA, other	3 terminals (2 devices) High ESD tolerance optimal for use in surge absorption
		NNCDxxDA Series	High ESD tolerance optimal for use in surge absorption
		RDxxS Series	2-terminal face-mount outline
		RKZ6.8Z4MFAKT	5 terminals (4 devices) low capacitance (4 pF) Low capacitance (4 pF) optimal for use in surge absorption for USB ports
		RKZxxKG/KJ Series	2 terminals SMD High ESD tolerance optimal for use in surge absorption
	Switching Diodes	HSC/D119, HSB2836/8	2-3 terminals SMD
		RKH0145/0160KU Series	2 terminals SMD High voltage tolerance optimal for use in surge absorption and high-voltage rectification
	Schottky Diodes	RKR, HRW Series	2-3 terminals SMD Small package, low capacitance, large current type
Tuner	LNA(Digital Tuner)	2SC3356,NE202930, other	Low distortion, Low noise
		NESG240033,NESG220033, other	Low distortion, Low noise, Protected high ESD
		μPC3221GV,μPC3234GV, other	Variable wide gain, Protected high ESD

*1 I²C : Inter-Integrated Circuit
*2 SPI : Serial Peripheral Interface

* = Under development

Related Application Notes/Sample Code

Title	Document No.
Power MOS FET Application Note	REJ05G0001-0200
R2A20112 Application Note*	-
R2A20115 Application Note*	-
R2A20117 Application Note*	-
R2A20118A Application Note*	-
R2A20132 Application Note*	-

*:Please contact your sales representative or contact us directly.

Related Boards

Name	Part No.
R2A20111 Evaluation Board*	-
R2A20112 Evaluation Board*	-
R2A20115 Evaluation Board*	-
R2A20117 Evaluation Board*	-
R2A20118A Evaluation Board*	-
R2A20132 Evaluation Board*	-

*:Please contact your sales representative or contact us directly.

Latest application information here.

<http://www.renesas.com/applications>

Notes:

1. All information included in this document is current as of the date this document is issued. Such information, however, is subject to change without any prior notice. Before purchasing or using any Renesas Electronics products listed herein, please confirm the latest product information with a Renesas Electronics sales office. Also, please pay regular and careful attention to additional and different information to be disclosed by Renesas Electronics such as that disclosed through our website.
 2. Renesas Electronics does not assume any liability for infringement of patents, copyrights, or other intellectual property rights of third parties by or arising from the use of Renesas Electronics products or technical information described in this document. No license, express, implied or otherwise, is granted hereby under any patents, copyrights or other intellectual property rights of Renesas Electronics or others.
 3. You should not alter, modify, copy, or otherwise misappropriate any Renesas Electronics product, whether in whole or in part.
 4. Descriptions of circuits, software and other related information in this document are provided only to illustrate the operation of semiconductor products and application examples. You are fully responsible for the incorporation of these circuits, software, and information in the design of your equipment. Renesas Electronics assumes no responsibility for any losses incurred by you or third parties arising from the use of these circuits, software, or information.
 5. When exporting the products or technology described in this document, you should comply with the applicable export control laws and regulations and follow the procedures required by such laws and regulations. You should not use Renesas Electronics products or the technology described in this document for any purpose relating to military applications or use by the military, including but not limited to the development of weapons of mass destruction. Renesas Electronics products and technology may not be used for or incorporated into any products or systems whose manufacture, use, or sale is prohibited under any applicable domestic or foreign laws or regulations.
 6. Renesas Electronics has used reasonable care in preparing the information included in this document, but Renesas Electronics does not warrant that such information is error free. Renesas Electronics assumes no liability whatsoever for any damages incurred by you resulting from errors in or omissions from the information included herein.
 7. Renesas Electronics products are classified according to the following three quality grades: "Standard", "High Quality", and "Specific". The recommended applications for each Renesas Electronics product depends on the product's quality grade, as indicated below. You must check the quality grade of each Renesas Electronics product before using it in a particular application. You may not use any Renesas Electronics product for any application categorized as "Specific" without the prior written consent of Renesas Electronics. Further, you may not use any Renesas Electronics product for any application for which it is not intended without the prior written consent of Renesas Electronics. Renesas Electronics shall not be in any way liable for any damages or losses incurred by you or third parties arising from the use of any Renesas Electronics product for an application categorized as "Specific" or for which the product is not intended where you have failed to obtain the prior written consent of Renesas Electronics. The quality grade of each Renesas Electronics product is "Standard" unless otherwise expressly specified in a Renesas Electronics data sheets or data books, etc.
 "Standard": Computers; office equipment; communications equipment; test and measurement equipment; audio and visual equipment; home electronic appliances; machine tools; personal electronic equipment; and industrial robots.
 "High Quality": Transportation equipment (automobiles, trains, ships, etc.); traffic control systems; anti-disaster systems; anti-crime systems; safety equipment; and medical equipment not specifically designed for life support.
 "Specific": Aircraft; aerospace equipment; submersible repeaters; nuclear reactor control systems; medical equipment or systems for life support (e.g. artificial life support devices or systems), surgical implantations, or healthcare intervention (e.g. excision, etc.), and any other applications or purposes that pose a direct threat to human life.
 8. You should use the Renesas Electronics products described in this document within the range specified by Renesas Electronics, especially with respect to the maximum rating, operating supply voltage range, movement power voltage range, heat radiation characteristics, installation and other product characteristics. Renesas Electronics shall have no liability for malfunctions or damages arising out of the use of Renesas Electronics products beyond such specified ranges.
 9. Although Renesas Electronics endeavors to improve the quality and reliability of its products, semiconductor products have specific characteristics such as the occurrence of failure at a certain rate and malfunctions under certain use conditions. Further, Renesas Electronics products are not subject to radiation resistance design. Please be sure to implement safety measures to guard them against the possibility of physical injury, and injury or damage caused by fire in the event of the failure of a Renesas Electronics product, such as safety design for hardware and software including but not limited to redundancy, fire control and malfunction prevention, appropriate treatment for aging degradation or any other appropriate measures. Because the evaluation of microcomputer software alone is very difficult, please evaluate the safety of the final products or system manufactured by you.
 10. Please contact a Renesas Electronics sales office for details as to environmental matters such as the environmental compatibility of each Renesas Electronics product. Please use Renesas Electronics products in compliance with all applicable laws and regulations that regulate the inclusion or use of controlled substances, including without limitation, the EU RoHS Directive. Renesas Electronics assumes no liability for damages or losses occurring as a result of your noncompliance with applicable laws and regulations.
 11. This document may not be reproduced or duplicated, in any form, in whole or in part, without prior written consent of Renesas Electronics.
 12. Please contact a Renesas Electronics sales office if you have any questions regarding the information contained in this document or Renesas Electronics products, or if you have any other inquiries.
- (Note 1) "Renesas Electronics" as used in this document means Renesas Electronics Corporation and also includes its majority-owned subsidiaries.
 (Note 2) "Renesas Electronics product(s)" means any product developed or manufactured by or for Renesas Electronics.

SALES OFFICES
<http://www.renesas.com>

 Refer to "<http://www.renesas.com>" for the latest and detailed information.

Renesas Electronics America Inc.

 2880 Scott Boulevard Santa Clara, CA 95050-2554, U.S.A.
 Tel: +1-408-588-6000, Fax: +1-408-588-6130

Renesas Electronics Canada Limited

 1101 Nicholson Road, Newmarket, Ontario L3Y 9C3, Canada
 Tel: +1-905-898-5441, Fax: +1-905-898-3220

Renesas Electronics Europe Limited

 Dukes Meadow, Millboard Road, Bourne End, Buckinghamshire, SL8 5FH, U.K
 Tel: +44-1628-585-100, Fax: +44-1628-585-900

Renesas Electronics Europe GmbH

 Arcadiastrasse 10, 40472 Düsseldorf, Germany
 Tel: +49-211-65030, Fax: +49-211-6503-1327^L
Renesas Electronics (China) Co., Ltd.

 7th Floor, Quantum Plaza, No.27 ZhiChunLu Haidian District, Beijing 100083, P.R.China
 Tel: +86-10-8235-1155, Fax: +86-10-8235-7679

Renesas Electronics (Shanghai) Co., Ltd.

 Unit 204, 205, AZIA Center, No.1233 Lujiazui Ring Rd., Pudong District, Shanghai 200120, China
 Tel: +86-21-5877-1818, Fax: +86-21-6887-7858 / -7898

Renesas Electronics Hong Kong Limited

 Unit 1601-1613, 16/F., Tower 2, Grand Century Place, 193 Prince Edward Road West, Mongkok, Kowloon, Hong Kong
 Tel: +852-2886-9318, Fax: +852 2886-9022/9044

Renesas Electronics Taiwan Co., Ltd.

 7F, No. 363 Fu Shing North Road Taipei, Taiwan
 Tel: +886-2-8175-9600, Fax: +886 2-8175-9670

Renesas Electronics Singapore Pte. Ltd.

 1 harbourFront Avenue, #06-10, keppel Bay Tower, Singapore 098632
 Tel: +65-6213-0200, Fax: +65-6278-8001

Renesas Electronics Malaysia Sdn.Bhd.

 Unit 906, Block B, Menara Amcorp, Amcorp Trade Centre, No. 18, Jln Persiaran Barat, 46050 Petaling Jaya, Selangor Darul Ehsan, Malaysia
 Tel: +60-3-7955-9390, Fax: +60-3-7955-9510

Renesas Electronics Korea Co., Ltd.

 11F., Samik Lavied' or Bldg., 720-2 Yeoksam-Dong, Kangnam-Ku, Seoul 135-080, Korea
 Tel: +82-2-558-3737, Fax: +82-2-558-5141

Latest application information here.
<http://www.renesas.com/applications>